

Schiebereinheiten

Slide units

Unités de tiroirs

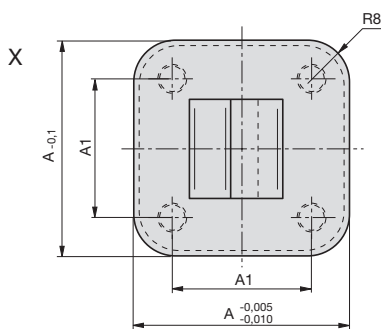
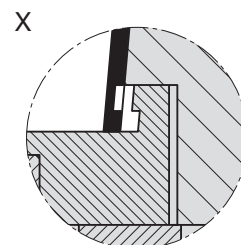
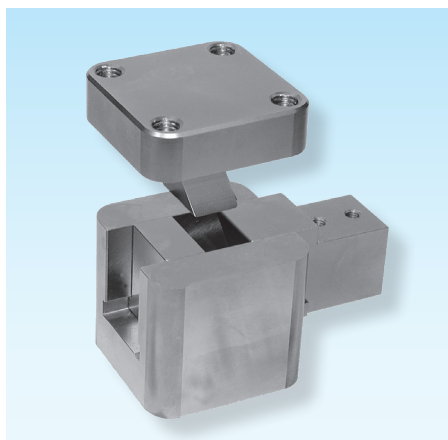

Schiebereinheit Z4296 für den Einsatz bei innenliegenden Hinterschnedungen.
Slide unit Z4296 for use with inner undercuts.
Unité de tiroir Z4296 pour les pièces à contre-dépouilles intérieures.

Z4296-

Mat.: 1.2343
52HRC

Z4296-Type

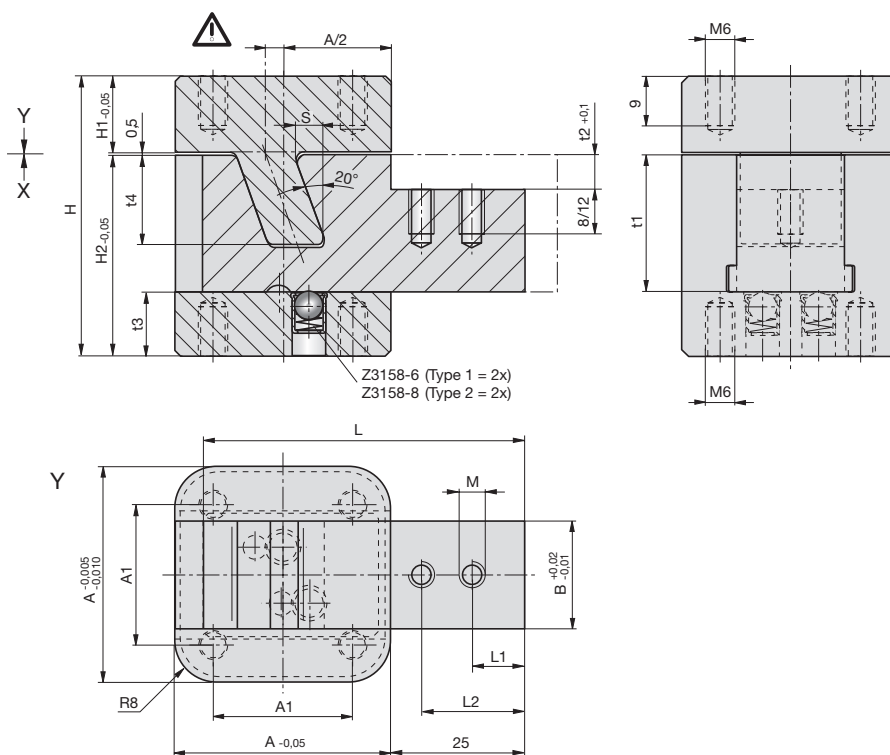

5

Type	A	B	A1	S	L	L1	L2	H	H1	H2	t1	t2	t3	t4	M
1	40	20	26	4,9	59,8	10	20	52	14,5	37	25	6	12	16	M4
2	60	35	46	9,9	84,0	6	18	72	14,5	57	40	10	17	30	M5