

### Gelenkstirnlochschlüssel

### Hinged pin wrench

### Clés à ergots articulées

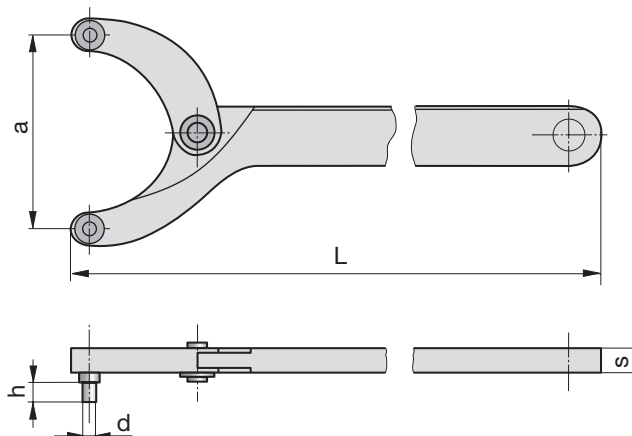

Z5103-

Z5103-d



d	a	h	L	s
3	18 - 40	4	150	5
4	18 - 40	5	150	5

6

### Maschinen-Gewindebohrer

### Machine tap sets

### Jeux de tarauds machine

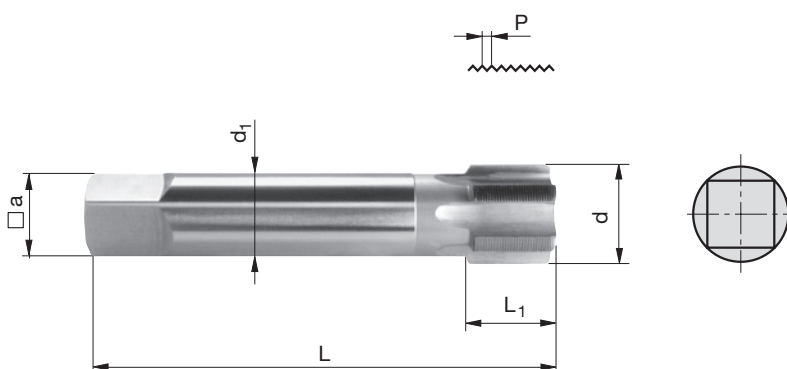
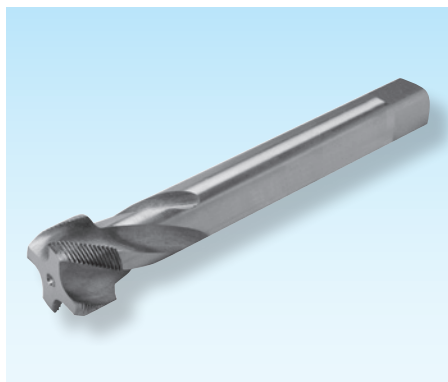

W8622-

Mat.: DIN 374C, HSS

W8622-dxP



Toleranz 6H,  
metrisches Feingewinde  
Tolerance 6H,  
metrical fine thread  
Tolérance 6H,  
filet fin métrique

d x P	L	L1	d1	a
M24 x 1,0	125	25	18	14,5
M26 x 1,0	140	26	18	14,5
M38 x 1,0	170	30	28	22,0
M50 x 1,0	190	33	36	29,0

D 3002A 07.2018