

Gasdruckfedern kompakte Bauform

Gas springs compact structural shape

Ressorts à gaz forme de construction compacte

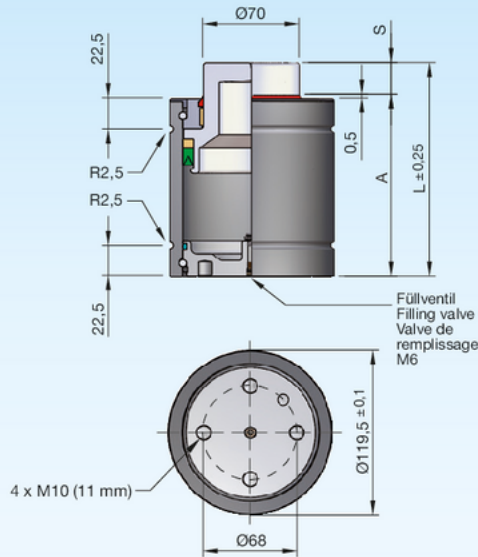

Einbauvarianten / Installation variants / Variantes de montage

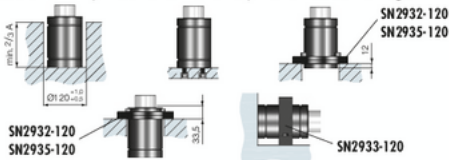

Druckmedium	Pressure medium	Médium de pression	Stickstoff (N₂)
Max. Fülldruck	Max. filling pressure	Pression de rempl. max.	150 bar
Min. Fülldruck	Min. filling pressure	Pression de rempl. min.	50 bar
Max. Betriebs-temperatur	Max. working temperature	Température de service max.	80 °C
Temperaturabhängige Druckerhöhung	Pressure increase due to temperature	Accroissement de pression sous l'influence de la temp.	0,33 %/1 °C
Instandhaltungssatz	Maintenance kit	Jeu de maintenance	SN2990-F1 1800
Max. Kolben-geschwindigkeit	Max. piston speed	Vitesse max. du piston	25 m/min.

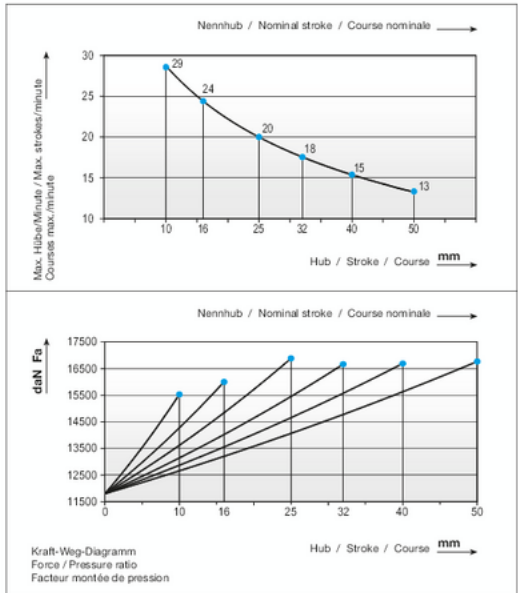

SN2900-11800-



SN2900-11800-S



S	daN	daN	bar	A	L	V [l]	Fa [cm ²]	kg
10	11800	15505	150	90	100	0,327	78,54	5,60
16	(+5%)	15975	150	110	126	0,479	78,54	6,39
25		16860	150	130	155	0,652	78,54	7,15
32		16640	150	155	187	0,861	78,54	7,96
40		16665	150	180	220	1,072	78,54	8,91
50		16740	150	210	260	1,326	78,54	10,15

S = Hub / Stroke / Course

bar = Fülldruck / Filling pressure / Pression de remplissage