

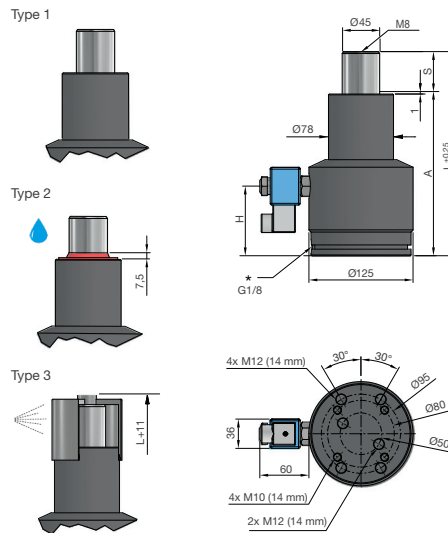

SN2884-2400

Controlled gas spring system



T: < 60 °C

V = 24 V DC, 17

S = stroke, bar = filling pressure
* Filling valve

S	Type	A	H	L	bar	daN1	daN2	Fa	Order No.
50	1	195	83.5	245	150	2400 (± 5%)	3180	15.90	SN2884-2400-50-1
50	2	195	83.5	245	150	2400 (± 5%)	3180	15.90	SN2884-2400-50-2
50	3	195	83.5	245	150	2400 (± 5%)	3180	15.90	SN2884-2400-50-3
75	1	232	95.5	307	150	2400 (± 5%)	3410	15.90	SN2884-2400-75-1
75	2	232	95.5	307	150	2400 (± 5%)	3410	15.90	SN2884-2400-75-2
75	3	232	95.5	307	150	2400 (± 5%)	3410	15.90	SN2884-2400-75-3
100	1	265	103.5	365	150	2400 (± 5%)	3520	15.90	SN2884-2400-100-1
100	2	265	103.5	365	150	2400 (± 5%)	3520	15.90	SN2884-2400-100-2
100	3	265	103.5	365	150	2400 (± 5%)	3520	15.90	SN2884-2400-100-3
125	1	300	113.5	425	150	2400 (± 5%)	3630	15.90	SN2884-2400-125-1
125	2	300	113.5	425	150	2400 (± 5%)	3630	15.90	SN2884-2400-125-2
125	3	300	113.5	425	150	2400 (± 5%)	3630	15.90	SN2884-2400-125-3

REQUIRED INFORMATION OF THE CUSTOMER

Working stroke¹⁾: ____ mm
 Press speed: ____ m/min
 Maximum press rate: ____ strokes/min

¹⁾The 100 % utilization of the stroke S reduces the max. possible working parameters.
 10 % stroke reserve is to be calculated in the tool construction.

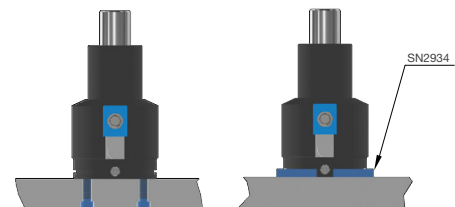

Pressure medium	N ²
Max. filling pressure	150 bar
Min. filling pressure	50 bar
Max. working temperature	60 °C
Pressure increase due to temperature	0,33 %/1 °C
Max. piston speed	0,4 m/s.
Max. recommended strokes	10-30* S/min.