

SN2884-3000

Controlled gas spring system

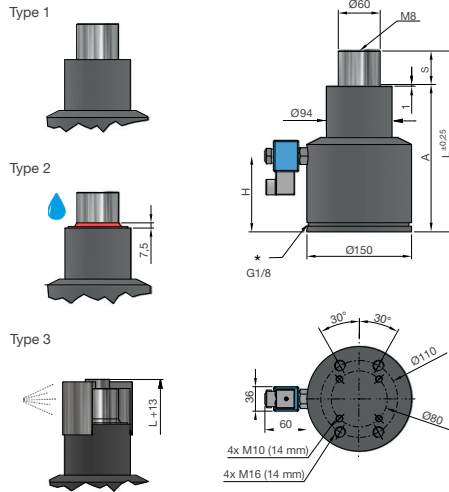

T: < 60 °C

V = 24 V DC, 17 W

S = stroke, bar = filling pressure
* Filling valve

S	Type	A	H	L	bar	daN1	daN2	Fa	Order No.
50	1	208	88.5	258	105	3000 (± 5%)	4065	28.27	SN2884-3000-50-1
50	2	208	88.5	258	105	3000 (± 5%)	4065	28.27	SN2884-3000-50-2
50	3	208	88.5	258	105	3000 (± 5%)	4065	28.27	SN2884-3000-50-3
75	1	245	100.5	320	105	3000 (± 5%)	4465	28.27	SN2884-3000-75-1
75	2	245	100.5	320	105	3000 (± 5%)	4465	28.27	SN2884-3000-75-2
75	3	245	100.5	320	105	3000 (± 5%)	4465	28.27	SN2884-3000-75-3
100	1	282	112.5	382	105	3000 (± 5%)	4515	28.27	SN2884-3000-100-1
100	2	282	112.5	382	105	3000 (± 5%)	4515	28.27	SN2884-3000-100-2
100	3	282	112.5	382	105	3000 (± 5%)	4515	28.27	SN2884-3000-100-3
125	1	319	124.5	444	105	3000 (± 5%)	4655	28.27	SN2884-3000-125-1
125	2	319	124.5	444	105	3000 (± 5%)	4655	28.27	SN2884-3000-125-2
125	3	319	124.5	444	105	3000 (± 5%)	4655	28.27	SN2884-3000-125-3

REQUIRED INFORMATION OF THE CUSTOMER

Working stroke¹⁾: ____ mm
 Press speed: ____ m/min
 Maximum press rate: ____ strokes/min

¹⁾The 100 % utilization of the stroke S reduces the max. possible working parameters.
 10 % stroke reserve is to be calculated in the tool construction.

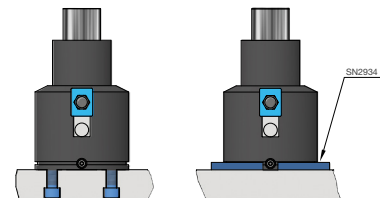

Pressure medium	N ²
Max. filling pressure	105 bar
Min. filling pressure	50 bar
Max. working temperature	60 °C
Pressure increase due to temperature	0,33 %/1 °C
Max. piston speed	0,5 m/s.
Max. recommed strokes	10-35* S/min.