

Gasdruckfedern

Gas springs

Ressorts à gaz

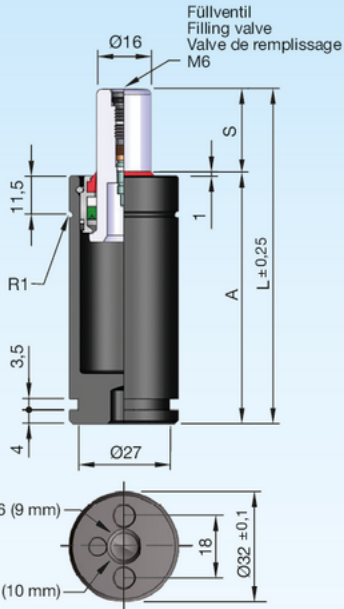

Einbauvarianten / Installation variants / Variantes de montage

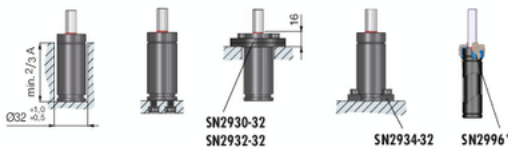

Druckmedium	Pressure medium	Médium de pression	Stickstoff (N ₂)
Max. Fülldruck	Max. filling pressure	Pression de rempl. max.	150 bar
Min. Fülldruck	Min. filling pressure	Pression de rempl. min.	25 bar
Max. Betriebstemperatur	Max. working temperature	Température de service max.	80 °C
Temperaturabhängige Druckerhöhung	Pressure increase due to temperature	Accroissement de pression sous l'influence de la temp.	0,33 %/1 °C
Instandhaltungssatz	Maintenance kit	Jeu de maintenance	SN2990-SP300
Max. Kolbengeschwindigkeit	Max. piston speed	Vitesse max. du piston	1,6 m/s

3

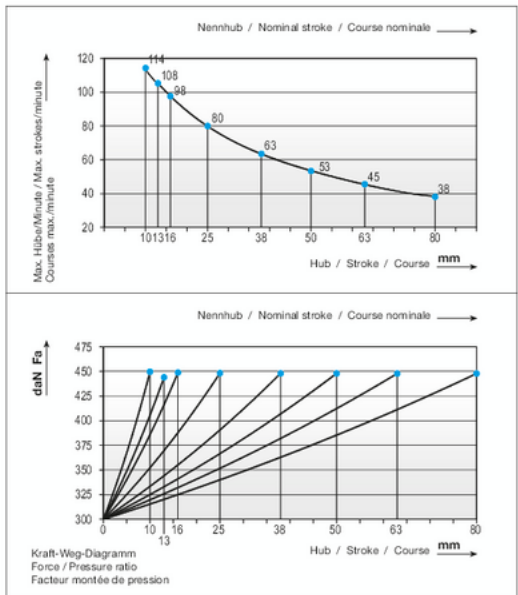

SN2820-P-300-

~ ISO 11901-1
~ VDI 3003

S



daN

bar

A

L

V [l]

Fa [cm²]

kg

SN2820-P-300-S



S = Hub / Stroke / Course

bar = Fülldruck / Filling pressure /
Pression de remplissage

* **SN2996** = Seite / Page **2.3.254**

10	300	450	150	60	70	0,006	2,01	0,31
13	(+5%)	445	150	62,7	75,4	0,008	2,01	0,33
16		450	150	66	82	0,010	2,01	0,34
25		450	150	75	100	0,015	2,01	0,38
38		450	150	88	126	0,023	2,01	0,43
50		450	150	100	150	0,030	2,01	0,48
63		450	150	113	176	0,038	2,01	0,53
80		450	150	130	210	0,049	2,01	0,61