

Gasdruckfedern MICROserie - VDI 3003

Gas springs MICROseries - VDI 3003

Ressorts à gaz MICROsérie - VDI 3003

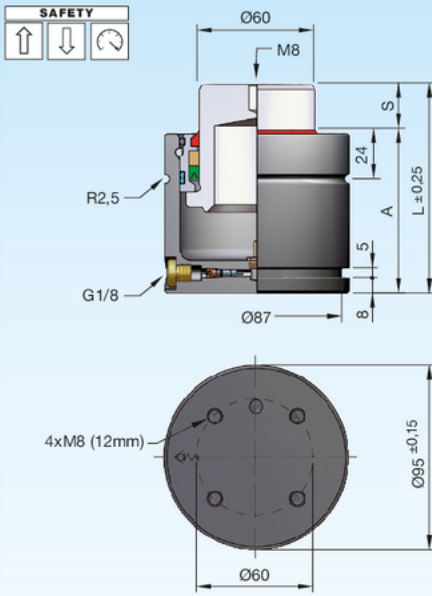

Einbauvarianten / Installation variants / Variantes de montage

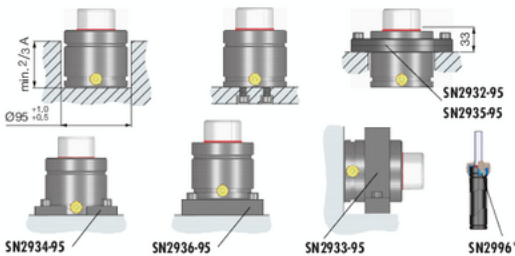

| Druckmedium | Pressure medium | Médium de pression | Stickstoff (N ₂) |
|-----------------------------------|--------------------------------------|--------------------------------------------------------|------------------------------|
| Max. Fülldruck | Max. filling pressure | Pression de rempl. max. | 150 bar |
| Min. Fülldruck | Min. filling pressure | Pression de rempl. min. | 35 bar |
| Max. Betriebs-temperatur | Max. working temperature | Température de service max. | 80 °C |
| Temperaturabhängige Druckerhöhung | Pressure increase due to temperature | Accroissement de pression sous l'influence de la temp. | 0,33 %/1 °C |
| Instandhaltungssatz | Maintenance kit | Jeu de maintenance | SN2990-M95 |
| Max. Kolbengeschwindigkeit | Max. piston speed | Vitesse max. du piston | 1,6 m/s |

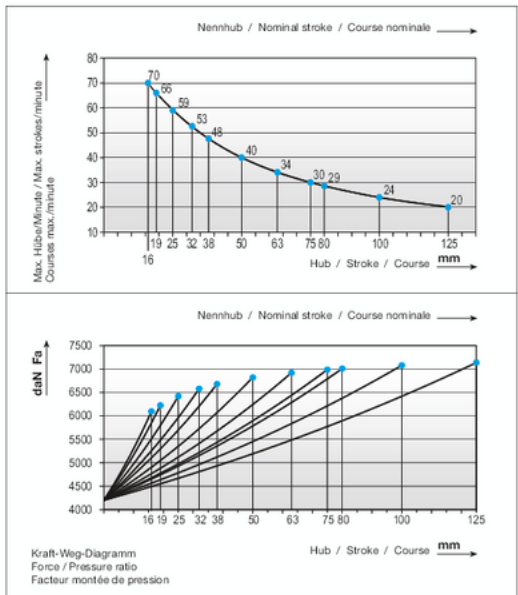

SN2808-4250-



SN2808-4250-S



S = Hub / Stroke / Course

bar = Fülldruck / Filling pressure / Pression de remplissage

* i SN2996 = Seite / Page 2.3.254

| S | daN | daN | bar | A | L | V [l] | Fa [cm ²] | kg |
|-----|-------|------|-----|-----|-----|-------|-----------------------|------|
| 16 | 4200 | 6155 | 150 | 74 | 90 | 0,146 | 28,27 | 2,80 |
| 19 | (±5%) | 6285 | 150 | 77 | 96 | 0,165 | 28,27 | 2,90 |
| 25 | | 6485 | 150 | 83 | 108 | 0,204 | 28,27 | 3,10 |
| 32 | | 6645 | 150 | 90 | 122 | 0,250 | 28,27 | 3,25 |
| 38 | | 6745 | 150 | 96 | 134 | 0,290 | 28,27 | 3,70 |
| 50 | | 6885 | 150 | 108 | 158 | 0,368 | 28,27 | 3,90 |
| 63 | | 6990 | 150 | 121 | 184 | 0,453 | 28,27 | 4,40 |
| 75 | | 7055 | 150 | 133 | 208 | 0,532 | 28,27 | 4,75 |
| 80 | | 7075 | 150 | 138 | 218 | 0,565 | 28,27 | 4,90 |
| 100 | | 7145 | 150 | 158 | 258 | 0,695 | 28,27 | 6,00 |
| 125 | | 7205 | 150 | 183 | 308 | 0,859 | 28,27 | 6,50 |