

Verlängerte Traverse
Extended steady
Tasseau prolongée

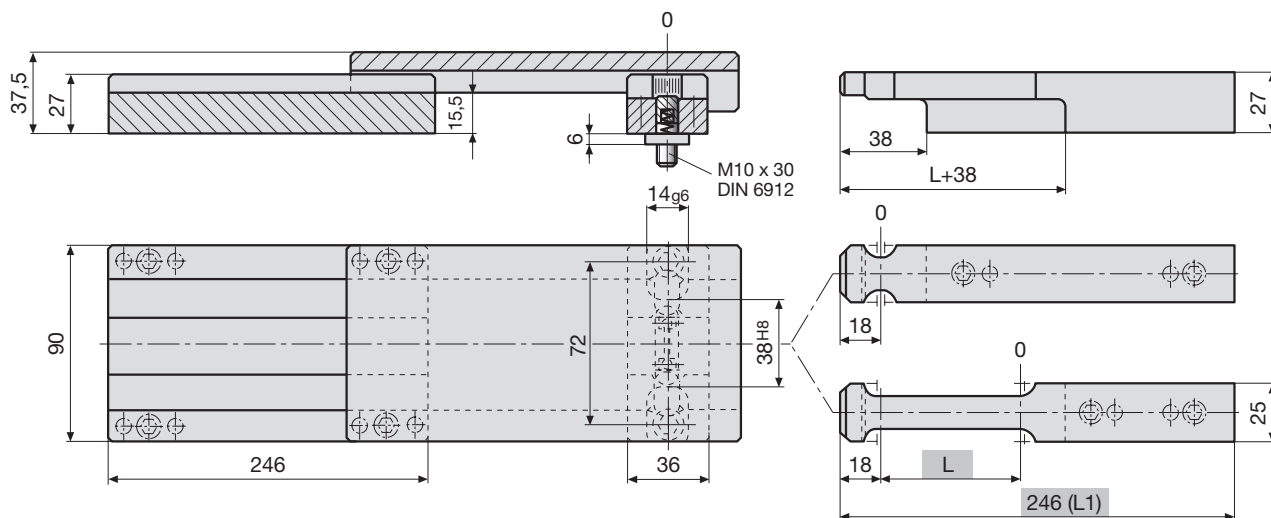

Type	L	Type	L
0-41	0	50-41	50
25-41	25	75-41	75

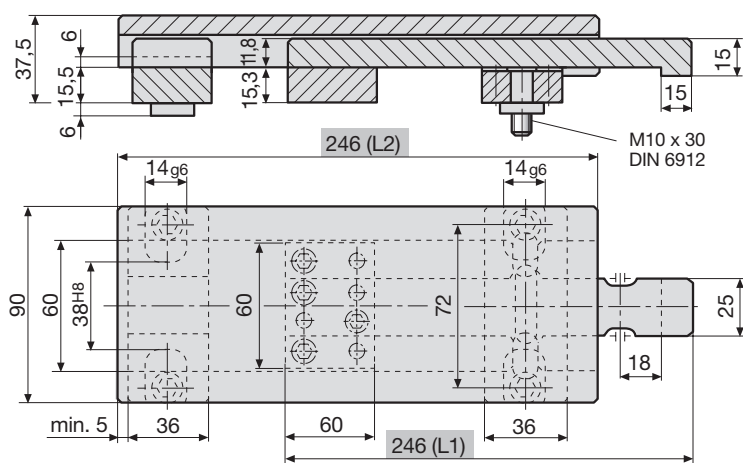





Zweistufenauswerfer
Two stage ejector
Ejecteur à deux étages



L , L1 , L2

in anderen Längen auf Anfrage
in other lengths on request
en autre longueurs sur demande

Type
1-0

Klinkenzüge		Latch locks		Ouvres-moules	
Z4-11-	deutsch 6.84-94 english 6.95-105 français 6.106-116				
 Z4-11-Type					
Z4-16-	deutsch 6.84-94 english 6.95-105 français 6.106-116				
 Z4-16-Type					
Z4-21-	deutsch 6.84-94 english 6.95-105 français 6.106-116				
 Z4-21-Type					

* deutsch 6.80
english 6.91
français 6.102

6

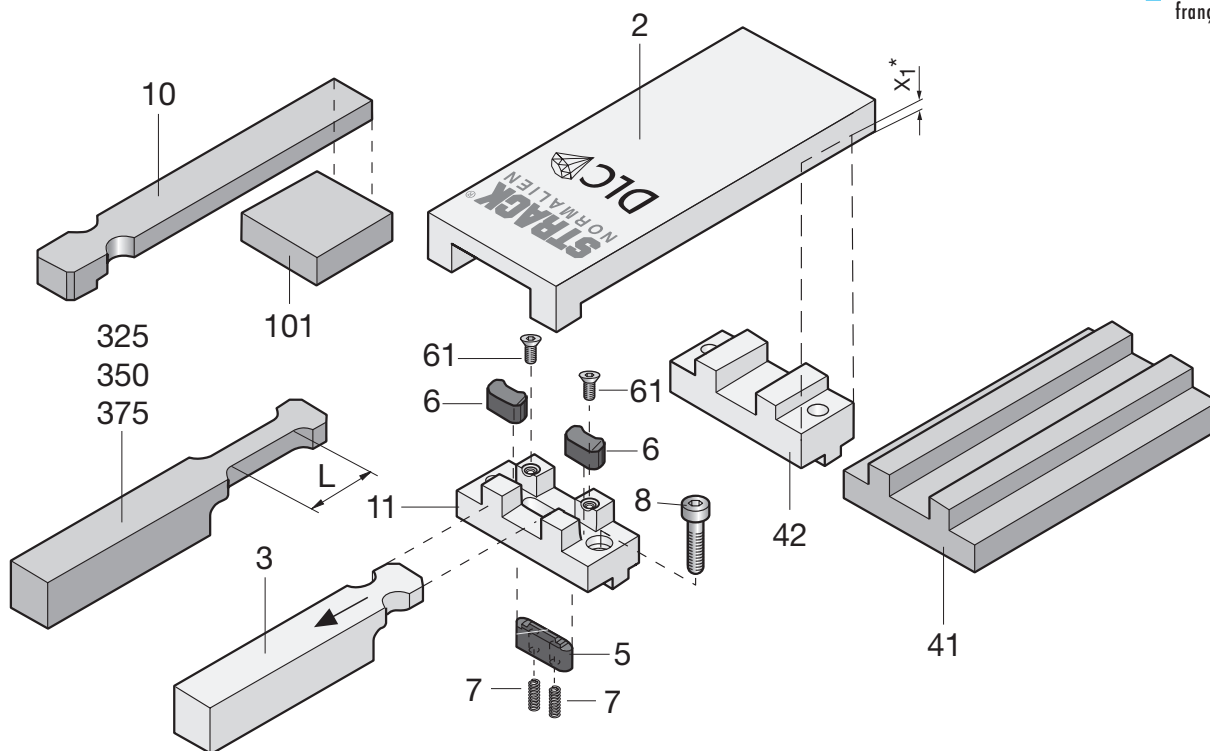

Stückliste
Parts list
Liste des pièces

 Z4-21-Type

Type	Pos. Item Pos.	Stück Quant. Nbr.	Bezeichnung	Description	Désignation	Mat.-Nr. Mat.-No Mat.Nr.
011	1	1	Klinkengehäuse	Latch housing	Support mobile	
02	2	1	Steuerplatte	Control plate	Plaque support	1.2162 ¹⁾
03	3	1	Zugleiste	Latch bar	Crochet	1.2162 ¹⁾
0325	325	1	Zugleiste m. Verzögerung, L = 25 mm	Latch bar with delay, L = 25 mm	Crochet de traction à retardement, L = 25 mm	1.2162 ¹⁾
0350	350	1	Zugleiste m. Verzögerung, L = 50 mm	Latch bar with delay, L = 50 mm	Crochet de traction à retardement, L = 50 mm	1.2162 ¹⁾
0375	375	1	Zugleiste m. Verzögerung, L = 75 mm	Latch bar with delay, L = 75 mm	Crochet de traction à retardement, L = 75 mm	1.2162 ¹⁾
041	41	1	Traverse, lang	Long steady	Tasseau long	1.1730
042	42	1	Traverse	Steady	Tasseau	1.1730
05	5	1	Sperre	Catch stop	Verrou	DLC
06	6	2	Raste	Catch	Clavette	DLC
10	10	1	Ausstoßerleiste	Reverse latch bar	Poussoir	1.2162 ¹⁾
101	101	1	Unterlage	Spacer	Support	1.1730

¹⁾ ~ 630 HV10
Einatzhärtetiefe (Eht)
Thickness of hardened layer = 0,4 - 0,6 mm
Épaisseur de la couche durcie

Normalien
Standard parts
Elements standard

 Strack Norm

Strack Norm	Pos. Item Pos.	Stück Quant. Nbr.	Bezeichnung	Description	Désignation	Mat.-Nr. Mat.-No Mat.Nr.
SN3550-M5-10	61	2	Senkschraube	Countersunk screw	Vis à tête fraisée	SN
SN2500-5-15	7	2	Druckfeder	Spring	Ressort de pression du verrou	SN
SN3540-M10-30	8	2	Zylinderschraube	Cap screw	Vis 6 pans creux	SN

Lieferumfang
Scope of delivery
Contenu de la livraison

Z4-21-0-0	Z4-21-25-0 Z4-21-50-0 Z4-21-75-0	Z4-21-0-41	Z4-21-25-41 Z4-21-50-41 Z4-21-75-41	Z4-21-1-0
011	011	011	011	011
02	02	02	02	02
03	0325	03	0325	
	0350		0350	
	0375		0375	
042	042	041	041	042
05	05	05	05	
06 + 061	06 + 061	06 + 061	06 + 061	06 + 061
07	07	07	07	
08	08	08	08	08
				10
				101

Klinkenzüge

Latch locks

Ouvres-moules

CAD-INFO

Z4-x-0-0
-25-
-50-
-75-

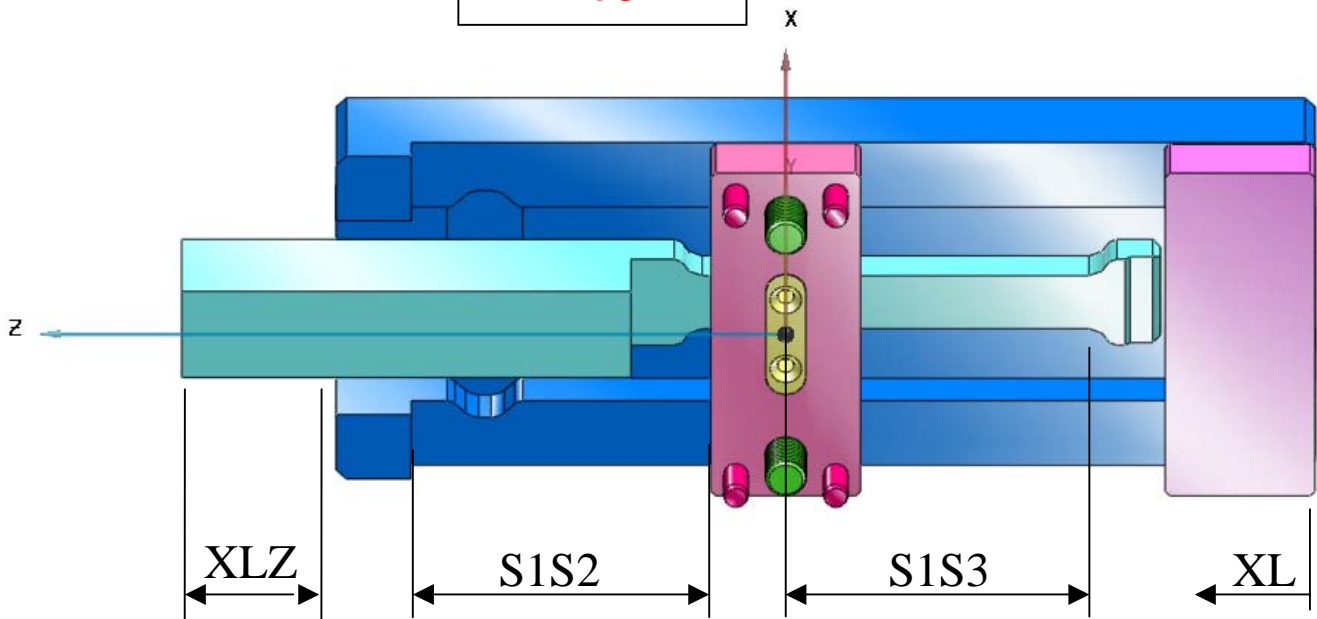
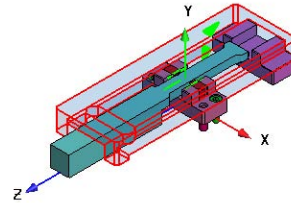

Z4-x-0-41
-25-41
-50-41
-75-41

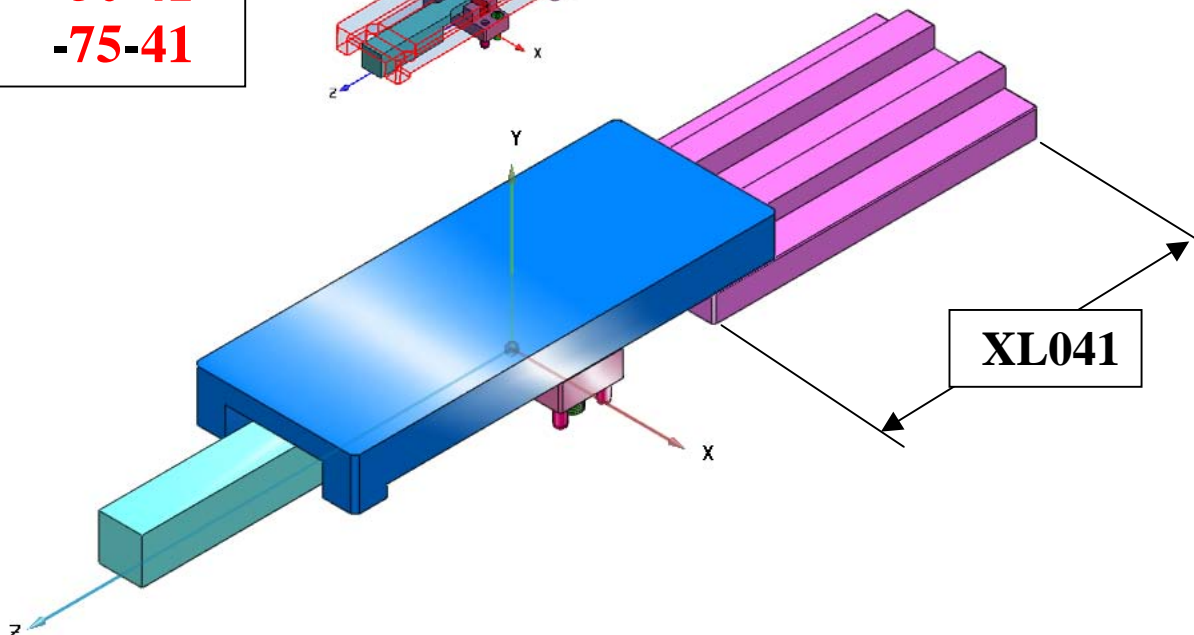
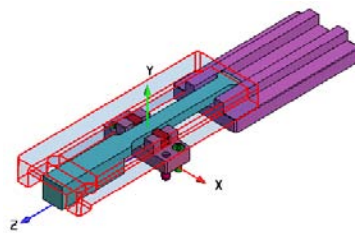

Klinkenzüge

Latch locks

Ouvres-moules

CAD-INFO

VAR=1

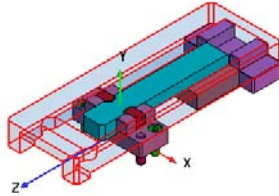

Z4-1-1-0

Z4-11-1-0

Z4-15-1-0

Z4-16-1-0

Z4-2-1-0

Z4-21-1-0

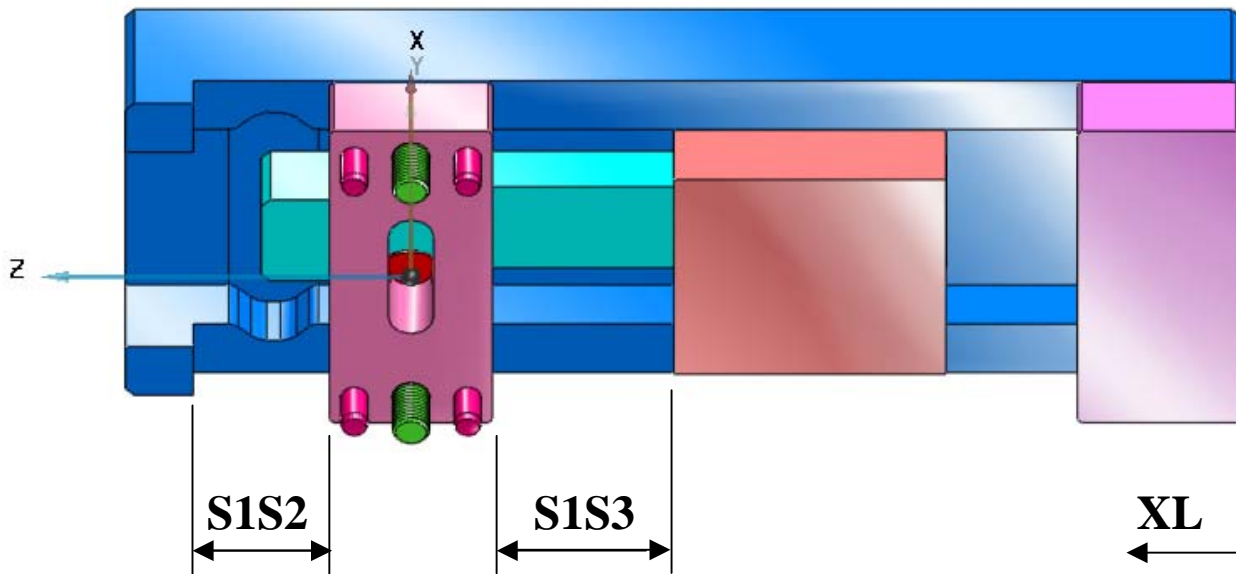

VAR=2

