

Gasdruckfedern mit Außengewinde

Gas springs with external thread

Ressorts à gaz avec un filet extérieur

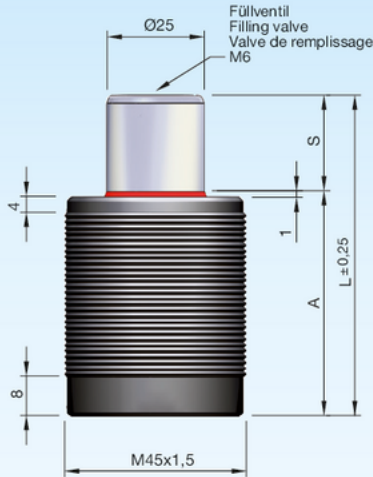

3

Druckmedium	Pressure medium	Médium de pression	Stickstoff (N₂)
Max. Fülldruck	Max. filling pressure	Pression de rempl. max.	150 bar
Min. Fülldruck	Min. filling pressure	Pression de rempl. min.	35 bar
Max. Betriebs-temperatur	Max. working temperature	Température de service max.	80 °C
Temperaturabhängige Druckerhöhung	Pressure increase due to temperature	Accroissement de pression sous l'influence de la temp.	0,33 %/1 °C
Instandhaltungssatz	Maintenance kit	Jeu de maintenance	SN2990-R45
Max. Kolben-geschwindigkeit	Max. piston speed	Vitesse max. du piston	1,6 m/s

Einbauvarianten / Installation variants / Variantes de montage

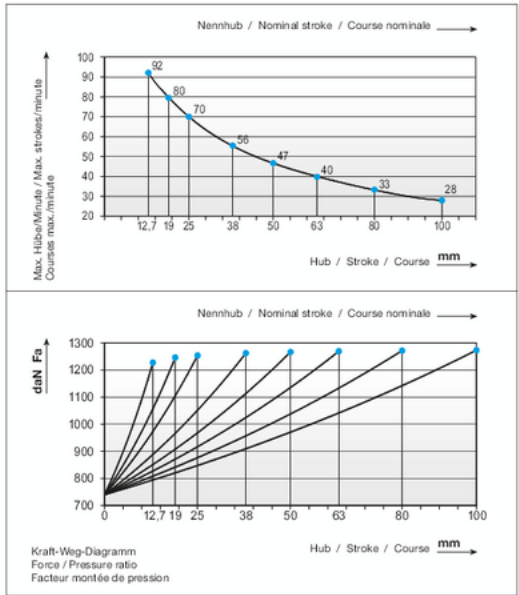
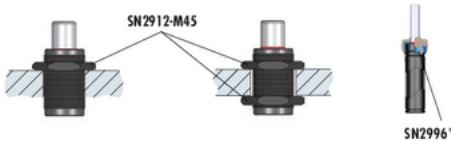

SN2910-M45-



SN2910-M45-S



S



daN
(±5%)



daN

bar

A

L

V

[l]

F_a

[cm²]

kg

S = Hub / Stroke / Course

bar = Fülldruck / Filling pressure / Pression de remplissage

* i SN2996 - Seite / Page 2.3.254

12,7
19
25
38
50
63
80
100

740
(±5%)

1220
1240
1250
1255
1260
1265
1265
1265

150
150
150
150
150
150
150
150

44,7
51
57
70
82
96
112
132

57,4
70
82
108
132
159
192
232

0,016
0,023
0,030
0,045
0,059
0,074
0,094
0,117

4,91
4,91
4,91
4,91
4,91
4,91
4,91
4,91

0,40
0,47
0,50
0,61
0,69
0,80
0,91
1,10