

Schnellspannsysteme

Quick-action clamping systems

Systèmes de serrage rapide

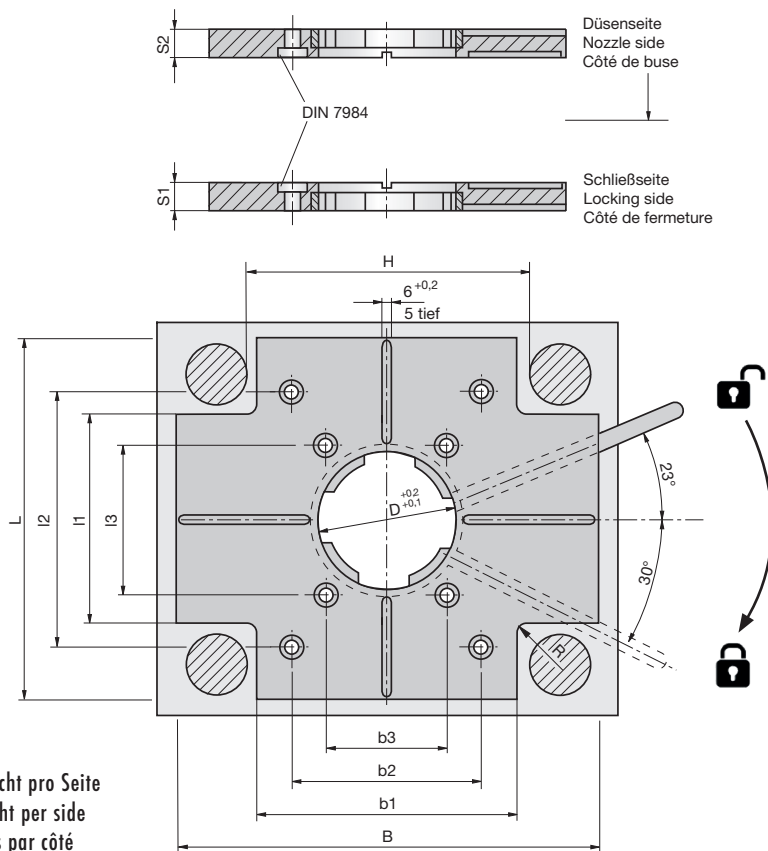
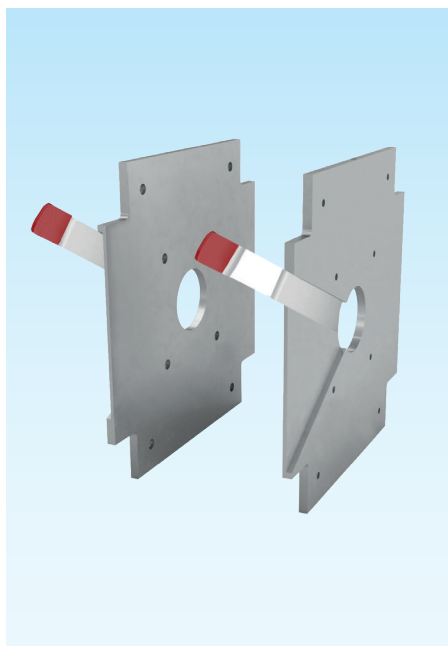

Z8062-

Mat.: ST



Z8062-H-D-S1-S2



Gewicht pro Seite
m = Weight per side
Poids par côté

H	D	S1	S2	m (kg)	B	L	b1	l1	b2	l2	b3	l3
170	100	17	17	400	296	296	150	150	70	140	-	-
	110	22	22	400	296	296	150	150	70	140	-	-
270	100	17	17	400	396	396	250	250	140	350	70	140
	110	17	17	400	396	396	250	250	140	350	70	140
	125	17	17	750	396	396	250	250	140	350	70	140
	100	22	22	400	396	396	250	250	140	350	70	140
320	110	22	22	400	396	396	250	250	140	350	70	140
	125	22	22	750	396	396	250	250	140	350	70	140
	100	17	17	400	446	446	300	280	210	350	140	140
	110	17	17	400	446	446	300	280	210	350	140	140
	125	17	17	750	446	446	300	280	210	350	140	140
	100	22	22	400	446	446	300	280	210	350	140	140
370	110	22	22	400	446	446	300	280	210	350	140	140
	125	22	22	750	446	446	300	280	210	350	140	140
	160	22	22	1000	446	446	300	280	210	350	140	140
	100	17	17	400	446	496	350	300	280	420	140	210
	110	17	17	400	446	496	350	300	280	420	140	210
	125	17	17	750	446	496	350	300	280	420	140	210
	100	22	22	400	446	496	350	300	280	420	140	210
	110	22	22	400	446	496	350	300	280	420	140	210



2

Schnellspannsysteme

Quick-action clamping systems

Systèmes de serrage rapide

2

H	D	S1	S2	m (kg)	B	L	b1	l1	b2	l2	b3	l3
370	125	22	22	750	446	496	350	300	280	420	140	210
	160	22	22	1000	446	496	350	300	280	420	140	210
420	100	17	17	400	546	546	400	350	280	420	210	210
	110	17	17	400	546	546	400	350	280	420	210	210
	125	17	17	750	546	546	400	350	280	420	210	210
	100	22	22	400	546	546	400	350	280	420	210	210
470	110	22	22	400	546	546	400	350	280	420	210	210
	125	22	22	750	546	546	400	350	280	420	210	210
	160	22	22	1000	546	546	400	350	280	420	210	210
	100	17	17	400	596	596	450	400	350	490	210	210
	110	17	17	400	596	596	450	400	350	490	210	210
	125	17	17	750	596	596	450	400	350	490	210	210
	100	22	22	400	596	596	450	400	350	490	210	210
	110	22	22	400	596	596	450	400	350	490	210	210
520	125	22	22	750	596	596	450	400	350	490	210	210
	160	22	22	1000	596	596	450	400	350	490	210	210
	100	17	17	400	646	696	500	450	350	560	210	210
	110	17	17	400	646	696	500	450	350	560	210	210
	125	17	17	750	646	696	500	450	350	560	210	210
	100	22	22	400	646	696	500	450	350	560	210	210
570	110	22	22	400	646	696	500	450	350	560	210	210
	125	22	22	750	646	696	500	450	350	560	210	210
	160	22	22	1000	646	696	500	450	350	560	210	210
	100	17	17	400	696	796	550	500	420	630	280	280
	110	17	17	400	696	796	550	500	420	630	280	280
	125	17	17	750	696	796	550	500	420	630	280	280
	100	22	22	400	696	796	550	500	420	630	280	280
	110	22	22	400	696	796	550	500	420	630	280	280

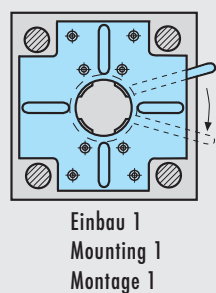
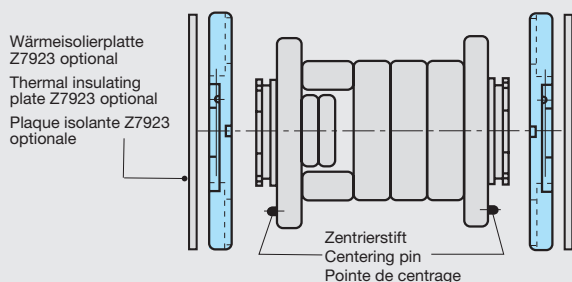

D 3002A 01.2022