

### Klinkenzüge

### Latch locks

### Ouvres-moules

DLC 

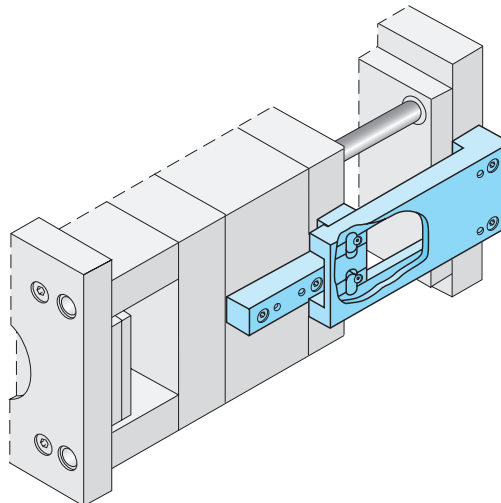
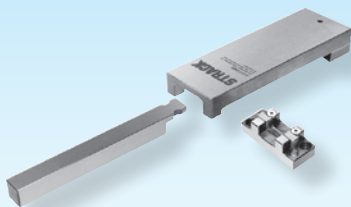

**Z4-2-**

**i** deutsch 6.84-94  
english 6.95-105  
français 6.106-116

 Z4-2-Type



6

Klinkengehäuse, Traverse und Zugleiste verstiftet  
Latch casing, top tie beam and tension strip pinned  
Boîtier d'ouvre-moule, traverse et barre de traction fixées par goupilles

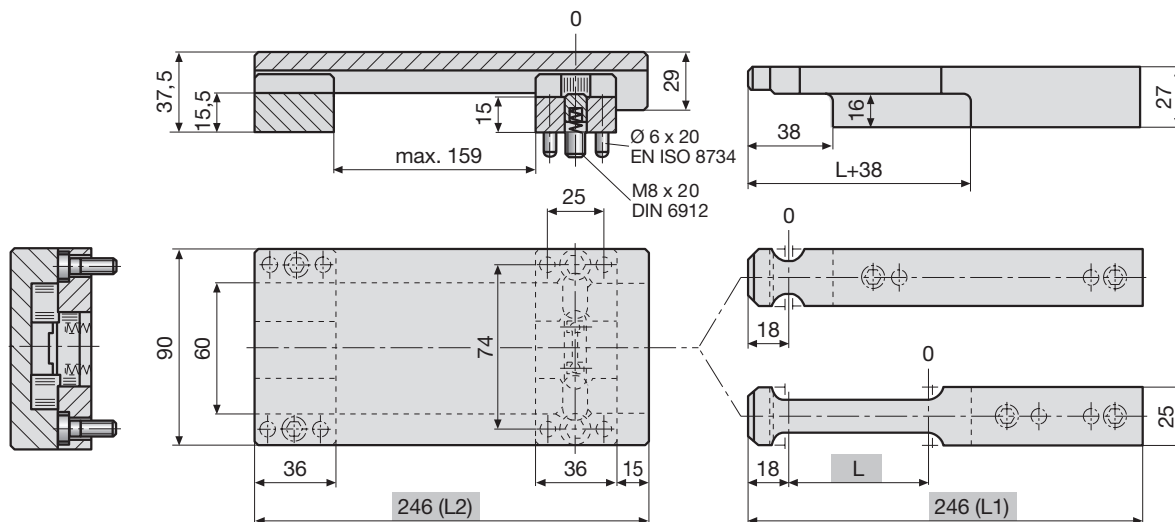

Type	L	Type	L
0-0	0	50-0	50
25-0	25	75-0	75

Verlängerte Traverse  
Extended steady  
Tasseau prolongée

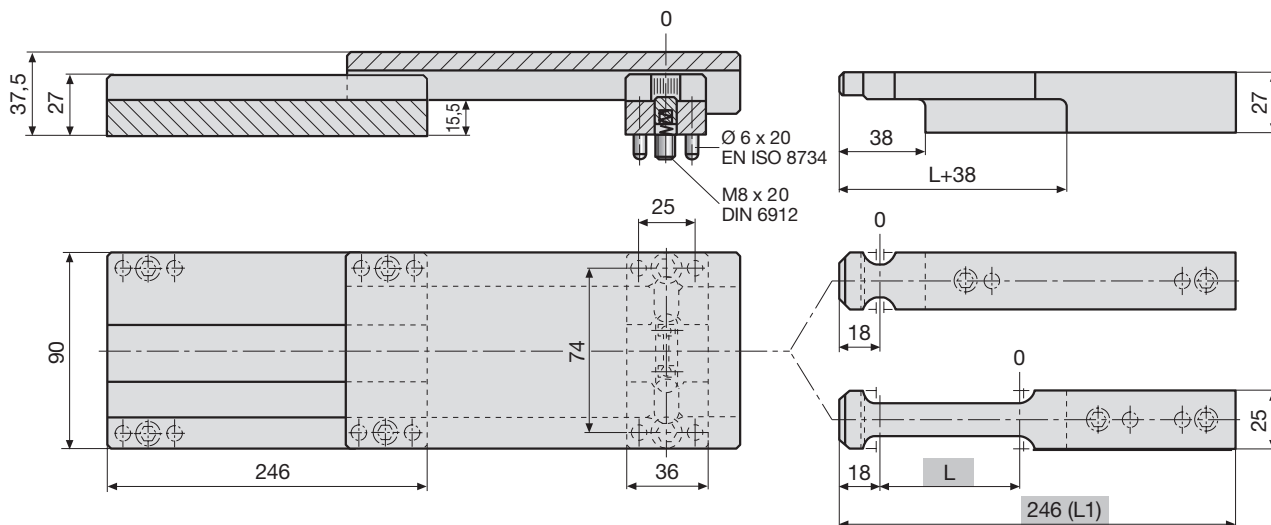





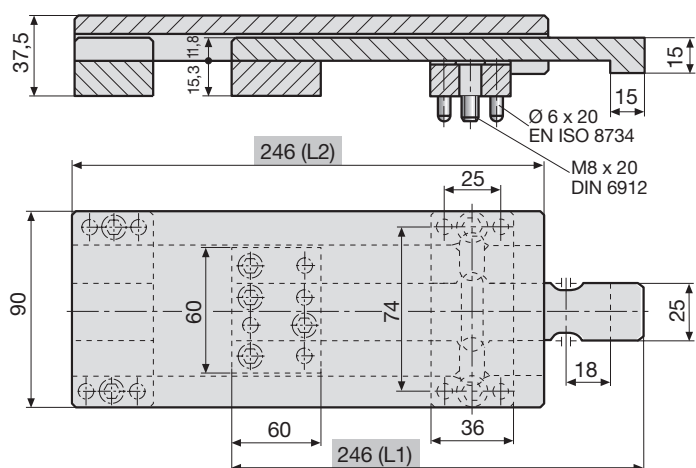

Type	L	Type	L
0-41	0	50-41	50
25-41	25	75-41	75

Zweistufenauswerfer  
Two stage ejector  
Éjecteur à deux étages



L , L1 , L2

in anderen Längen auf Anfrage  
in other lengths on request  
en autre longueurs sur demande

Klinkenzüge		Latch locks		Ouvres-moules	
<b>Z4-1-</b>	<b>i</b> deutsch 6.84-94 english 6.95-105 français 6.106-116				
 Z4-1-Type					
<b>Z4-15-</b>	<b>i</b> deutsch 6.84-94 english 6.95-105 français 6.106-116				
 Z4-15-Type					
<b>Z4-2-</b>	<b>i</b> deutsch 6.84-94 english 6.95-105 français 6.106-116				
 Z4-2-Type					

6

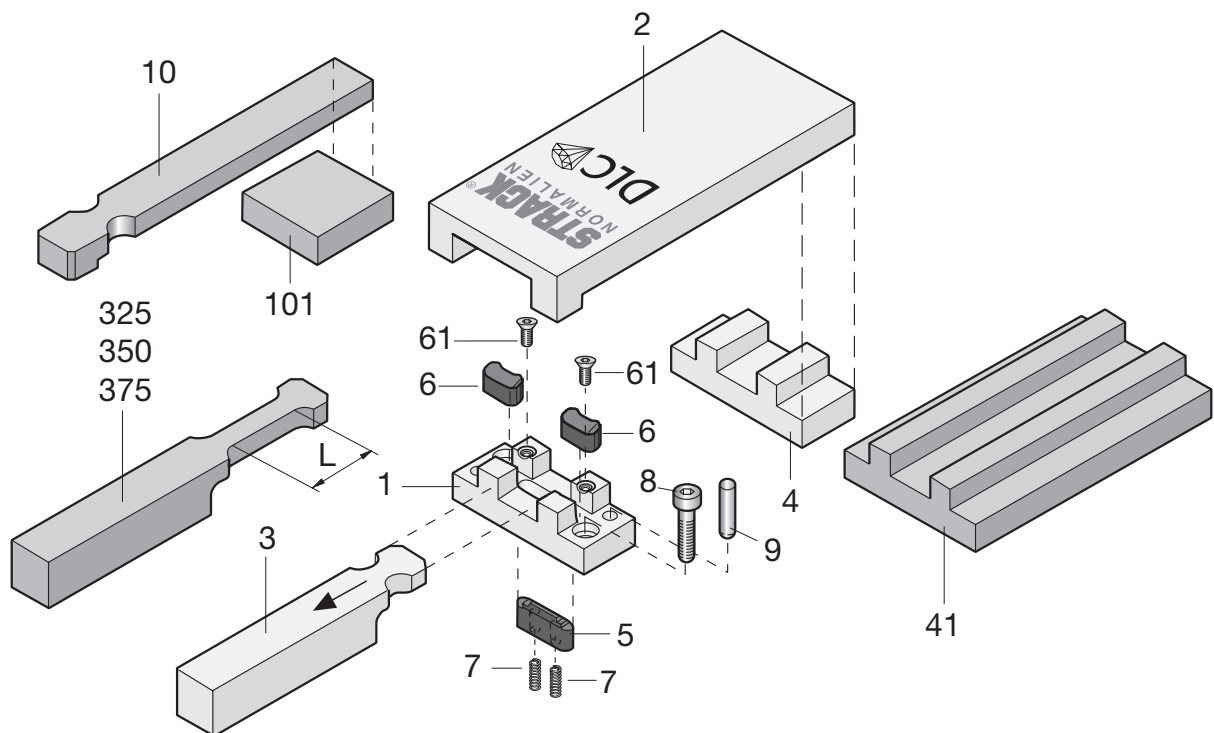

D 3002A 07.2018

Stückliste  
Parts list  
Liste des pièces



Z4-2-Type

Type	Pos. Item Pos.	Stück Quant. Nbr.	Bezeichnung	Description	Désignation	Mat.-Nr. Mat.-No Mat.Nr.
01	1	1	Klinkengehäuse	Latch housing	Support mobile	
02	2	1	Steuerplatte	Control plate	Plaque support	1.2162 <sup>1)</sup>
03	3	1	Zugleiste	Latch bar	Crochet	1.2162 <sup>1)</sup>
0325	325	1	Zugleiste m. Verzögerung, L = 25 mm	Latch bar with delay, L = 25 mm	Crochet de traction à retardement, L = 25 mm	1.2162 <sup>1)</sup>
0350	350	1	Zugleiste m. Verzögerung, L = 50 mm	Latch bar with delay, L = 50 mm	Crochet de traction à retardement, L = 50 mm	1.2162 <sup>1)</sup>
0375	375	1	Zugleiste m. Verzögerung, L = 75 mm	Latch bar with delay, L = 75 mm	Crochet de traction à retardement, L = 75 mm	1.2162 <sup>1)</sup>
04	4	1	Traverse	Steady	Tasseau	1.1730
041	41	1	Traverse, lang	Long steady	Tasseau long	1.1730
05	5	1	Sperre	Catch stop	Verrou	DLC
06	6	2	Raste	Catch	Clavette	DLC
10	10	1	Ausstoßerleiste	Reverse latch bar	Poussoir	1.2162 <sup>1)</sup>
101	101	1	Unterlage	Spacer	Support	1.1730

<sup>1)</sup> ~ 630 HV10  
Einatzhärtetiefe (Eht)  
Thickness of hardened layer = 0,4 - 0,6 mm  
Épaisseur de la couche durcie

Normalien  
Standard parts  
Elements standard



Strack Norm

Strack Norm	Pos. Item Pos.	Stück Quant. Nbr.	Bezeichnung	Description	Désignation	Mat.-Nr. Mat.-No Mat.Nr.
SN3550-M5-10	61	2	Senkschraube	Countersunk screw	Vis à tête fraisée	SN
SN2500-5-15	7	2	Druckfeder	Spring	Ressort de pression du verrou	SN
SN3540-M8-20	8	2	Zylinderschraube	Cap screw	Vis 6 pans creux	SN
SN1973-6-20	9	4	Zylinderstift	Dowel pin	Goupille cylindrique	SN

Lieferumfang  
Scope of delivery  
Contenu de la livraison

Z4-2-0-0	Z4-2-25-0 Z4-2-50-0 Z4-2-75-0	Z4-2-0-41	Z4-2-25-41 Z4-2-50-41 Z4-2-75-41	Z4-2-1-0
01	01	01	01	01
02	02	02	02	02
03	0325	03	0325	
	0350		0350	
	0375		0375	
04	04	041	041	04
05	05	05	05	
06 + 061	06 + 061	06 + 061	06 + 061	06 + 061
07	07	07	07	
08	08	08	08	08
09	09	09	09	09
				10
				101

Klinkenzüge

Latch locks

Ouvres-moules

### CAD-INFO

**Z4-x-0-0**

**-25-**

**-50-**

**-75-**

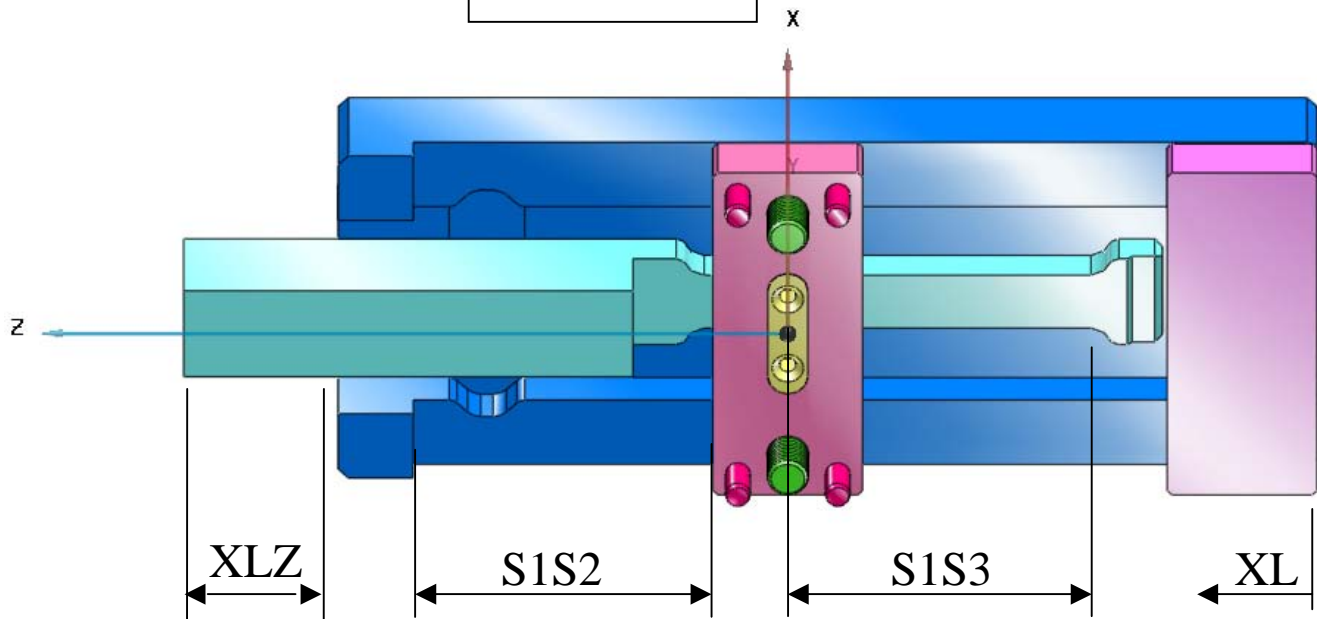
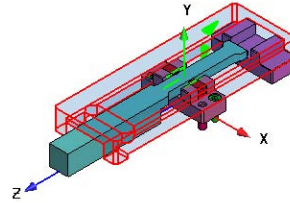

**Z4-x-0-41**

**-25-41**

**-50-41**

**-75-41**

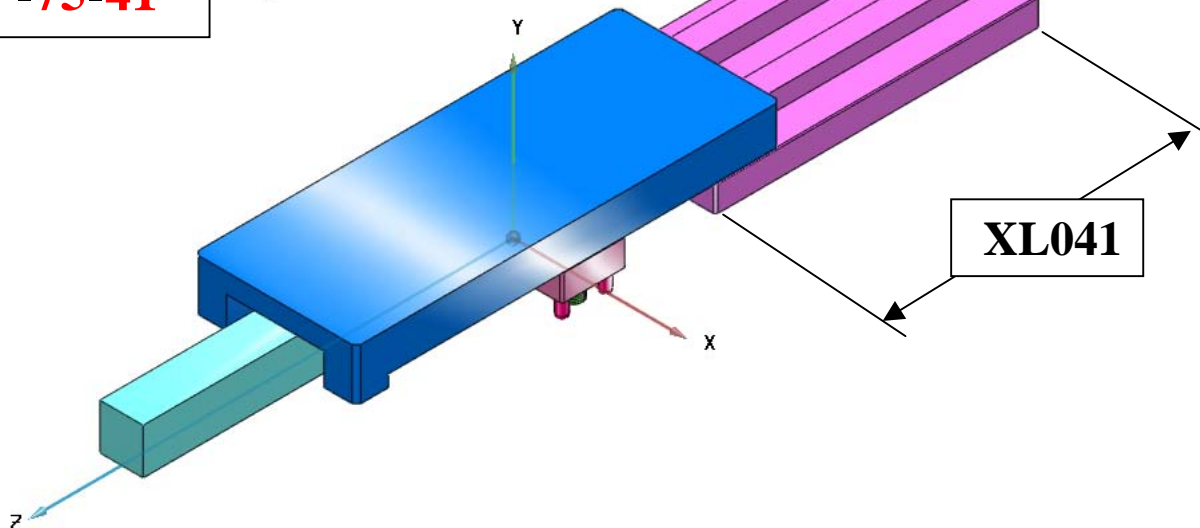
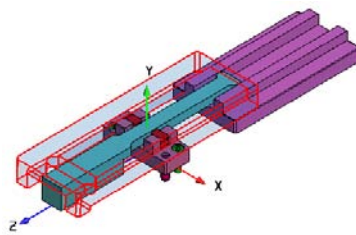

Klinkenzüge

Latch locks

Ouvres-moules

CAD-INFO

Z4-1-1-0

Z4-11-1-0

Z4-15-1-0

Z4-16-1-0

Z4-2-1-0

Z4-21-1-0

VAR=1

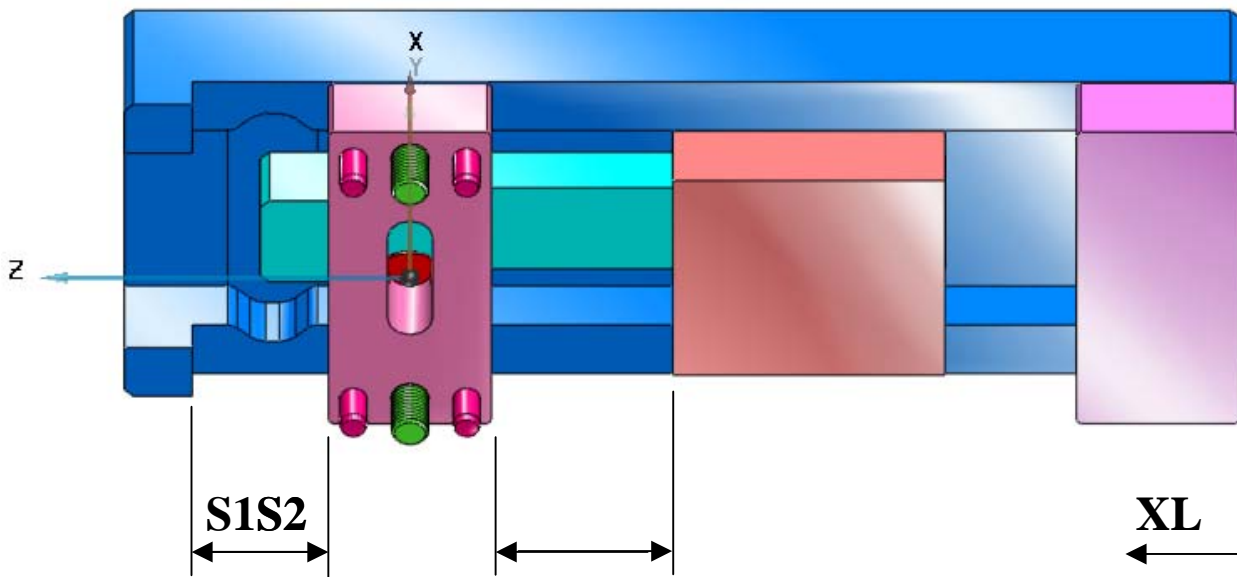
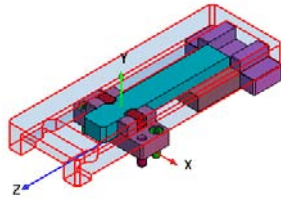

VAR=2

