

## Gasdruckfedern Standard, ISO, VDI, CNOMO

## Gas springs Standard, ISO, VDI, CNOMO

## Ressorts à gaz Standard, ISO, VDI, CNOMO

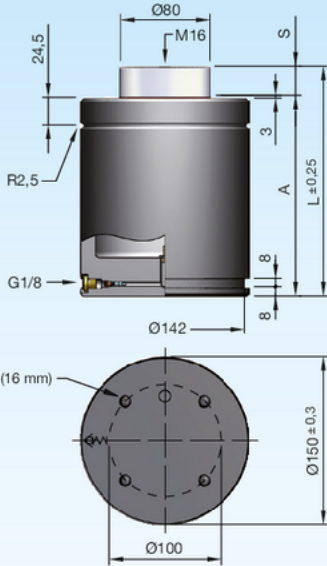

Druckmedium	Pressure medium	Médium de pression	<b>Stickstoff (N<sub>2</sub>)</b>
Max. Fülldruck	Max. filling pressure	Pression de rempl. max.	<b>150 bar</b>
Min. Fülldruck	Min. filling pressure	Pression de rempl. min.	<b>35 bar</b>
Max. Betriebs-temperatur	Max. working temperature	Température de service max.	<b>80 °C</b>
Temperaturabhängige Druckerhöhung	Pressure increase due to temperature	Accroissement de pression sous l'influence de la temp.	<b>0,33 %/1 °C</b>
Instandhaltungssatz	Maintenance kit	Jeu de maintenance	<b>SN2990-S7500</b>
Max. Kolbengeschwindigkeit	Max. piston speed	Vitesse max. du piston	<b>1,6 m/s</b>

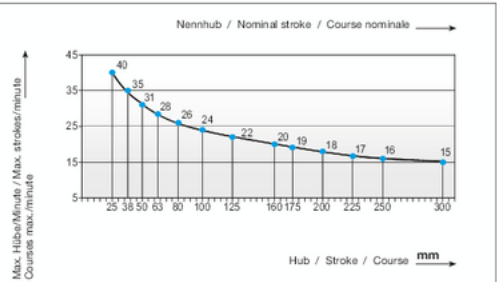

### Einbauvarianten / Installation variants / Variantes de montage

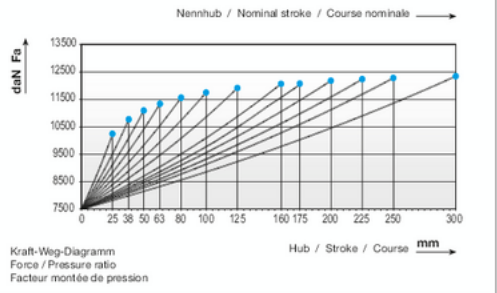
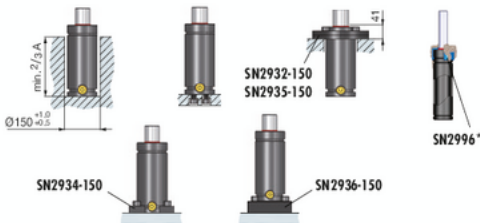

### SN2820-7500-

ISO 11901-1  
CNOMO E.24.54.815.N  
VDI 3003



SN2820-7500-S



S = Hub / Stroke / Course

bar = Fülldruck / Filling pressure / Pression de remplissage

\* i SN2996 = Seite / Page 2.3.254

S	daN	daN	bar	A	L	V [l]	Fa [cm <sup>2</sup> ]	kg
25	7500	10295	150	180	205	0,469	50,27	19,50
38	(+5%)	10830	150	193	231	0,629	50,27	20,60
50		11150	150	205	255	0,776	50,27	21,50
63		11400	150	219	282	0,936	50,27	22,30
80		11625	150	235	315	1,144	50,27	23,70
100		11815	150	255	355	1,390	50,27	25,40
125		11975	150	280	405	1,697	50,27	27,00
160		12130	150	315	475	2,126	50,27	30,60
175		12175	150	330	505	2,310	50,27	31,40
200		12245	150	355	555	2,617	50,27	33,80
225		12295	150	380	605	2,924	50,27	35,60
250		12340	150	405	655	3,230	50,27	37,40
300		12405	150	455	755	3,844	50,27	40,10