

# CONTROLLED GAS SPRING SYSTEMS OPERATING INSTRUCTIONS

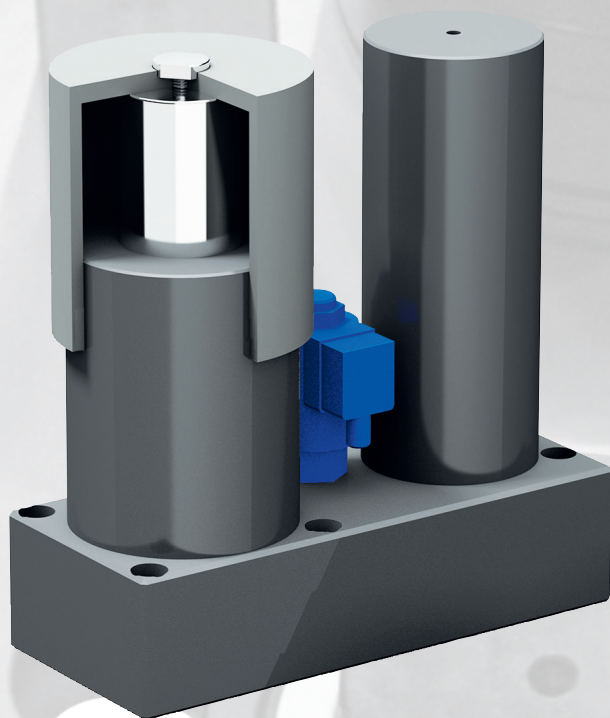

Manufactured by

**TECAPRES®**



Service and distribution in  
countries D, A and CH by

**STRACK®**

**NORMALIEN**

### Controlled gas spring systems SN2875 / SN2882 / SN2883 / SN2884

Content	Page
Safety instructions .....	4
After receipt of delivery .....	5
1. Features .....	6
2. Preparation of tool and press .....	7
3. Installation .....	8
4. Control panels SN2960 / SN2962 / SN2963 / SN2965 .....	9
4.1 Types .....	9-10
5. Installation.....	11
5.1 Installation with special design .....	11
5.1.1 SN2960 .....	11
5.1.2 SN2962 .....	11
5.1.3 SN2963 .....	12
5.1.4 SN2965 .....	12
6. Initial start-up .....	13
6.1 Filling of the system pressure .....	13-14
6.2 Modification of the system pressure of the gas springs .....	14
6.3 Release of the pressure at a gas spring bloc .....	15
6.4 Increase of the pressure at a gas spring .....	15
7. Pressurecontroller.....	16-17
7.1 Safety features .....	18
8. Production .....	19
9. Maintenance of the system .....	19
9.1 Safety data sheet concerning the used hydraulic oil .....	20
10. Standstill and storage .....	20

	Page
11. <b>ANNEX</b> .....	21
11.1 Functional operation .....	21
11.2 Catalogue page SN2875-4500 .....	22
11.3 Catalogue page SN2882-4500 .....	23
11.4 Catalogue page SN2883-4500 .....	24
11.5 Catalogue page SN2883-4500 .....	25
11.6 Important information for the order .....	26-27
11.7 Connection electromagnetic coil .....	28
11.7.1 Technical data magnetic coil .....	29-30
11.8 Filling pressure tables (examples) .....	31-32
11.9 Examples for mounting plates ready to be installed with controlled gas spring system .....	33
11.10 Common errors .....	34

### Controlled gas spring systems SN2875 / SN2882 / SN2883 / SN2884

## Safety features

Please absolutely observe!



Please absolutely read and observe the following safety instructions before installation and initial operation and all further works on the STRACK nitrogen gas spring system!

The special design of the “Controlled nitrogen gas spring system” must be used according to these operating instructions. Upon release of a new version, these operating instructions lose their validity.

The initial start-up and operation of the STRACK nitrogen gas spring system must exclusively be done by personnel which has been trained and instructed by STRACK GmbH & Co.KG (hereinafter referred to as STRACK).

Service- and maintenance works at the STRACK nitrogen gas spring system may only be effected by personnel with good technical knowledge, trained and instructed by STRACK.

### **ATTENTION!**

If this STRACK nitrogen gas spring system is improperly used or dismantled, the following things threaten:

- Risks to the health,
- Dangers for the STRACK nitrogen gas spring system and further assets of the user,
- Dangers for the efficiency of the STRACK nitrogen gas spring system, the loss of warranty,
- The loss of warranty claims.

During all works at the STRACK nitrogen gas spring system the applicable operating safety regulation paragraph 3 must be considered.

Press, tool and peripheral equipment must be suitable, prepared and adapted for the use of the STRACK nitrogen gas spring system.

Before and during the service- and maintenance works there is an increased risk of accident. Therefore, these works may only be performed at the non-pressurized gas spring system.

Damaged components must not be used again.

The exchange of individual components must be discussed with STRACK.

### Controlled gas spring systems SN2875 / SN2882 / SN2883 / SN2884

## After receipt of delivery

Examine the delivery for external damages before opening.  
Please immediately submit a complaint to the transport company which delivered the consignment in the event of damage.

Compare the content of your delivery with the bill of delivery respectively the enclosed piece list (see annex). Check if all pieces listed on the bill of delivery are included and unpacked.

### **Only then dispose the transport- and packing material.**

In the case of damages to the content without externally visible damage of the packaging, please do not send it back for repair or replacement.

Please contact STRACK NORMA GmbH & Co.KG in Lüdenscheid to get further information:

**Phone: +49 2351 / 8701 - 0** (head office)

### Controlled gas spring systems SN2875 / SN2882 / SN2883 / SN2884

## 1. Features

The execution of this STRACK nitrogen gas springs system is a **“CONTROLLED GAS SPRING SYSTEM”**

These gas springs can be:

- Installed individually
- In combination with a control panel

This CONTROLLED GAS SPRING SYSTEM is a **COMBINED SYSTEM**, consisting of:

- One (or more) mounting plates
- CONTROLLED GAS SPRINGS (execution according to the order)
- A control panel (execution according to the order)
- Optionally with one or more pressure controllers
- One or more high-pressure connecting hoses SN2952/53/54-length
- Connecting cable for the control of electromagnetic valves

The systems SN2882 and SN2883 additionally have a protective cap on the piston rod, these controlled gas springs systems were especially developed for the hot forming.

In this system nitrogen with a purity level of  $\geq 99,8$  Vol.-% is used as pressure medium.

Cylinder size, - number, -position and filling pressure (adapted to the respective case of application) determine the available force.

When the piston rod retracts, the hydraulic fluid is pushed aside in the accumulator. The filling pressure applied in the accumulator determines the cylinder force. If no voltage is given on the electromagnetic valve the gas spring will extend immediately again.

If in the bottom dead centre of the press a voltage is given on the electromagnetic valve the piston is held in its position and only extends again after removal of the voltage at the electromagnetic valve (spring back max. about 0,2 mm).

#### **ATTENTION!**



The electromagnetic valve is available with different operating voltages. Please absolutely observe that the right voltage is applied in order not to influence service life and function.

### Controlled gas spring systems SN2875 / SN2882 / SN2883 / SN2884

## 2. Preparation of tool and press

According to the specifications of STRACK NORMA tool, press and peripheral devices must be suitable, prepared and adapted for the use of the STRACK nitrogen spring systems.

After the extension of the press respectively the tool, the cylinders of the STRACK nitrogen gas spring systems must stand free of pre-stressing in the extended position. Thereby the piston rods are again centrally aligned after each stroke.

- Care must be taken that the transfer of the forces will occur vertically to the piston rods of the cylinders. Hereby the service life of the STRACK nitrogen-gas spring system is considerably increased.
- Protect controlled gas spring unit against water (short-circuit hazard).
- Lead off fluids (for example water or drawing oils) selectively by a drainage.

### Controlled gas spring systems SN2875 / SN2882 / SN2883 / SN2884

## 3. Installation

The nitrogen spring systems has already been premounted by STRACK and has been checked for function and tightness.

The gas springs must not be demounted, because otherwise air enters in the system and the springs don't function any more, moreover at demounting the warranty expires.

### 3.1 Application of controlled gas springs in single use

Controlled gas springs can be used individually. Here you can use the autonomously filled gas spring.

However, for higher comfort, it is recommended to use a control panel, for example SN2960.

This panel allows the control and adjustment of the system pressure on the operator side of the tool without having to demount the tool for the accessibility of the gas spring.

Further explanations see chapter 5.

Pay attention to a kink-free laying of the electrical cable and as the case may be of the high-pressure hose. Secure electrical cables and high-pressure hoses always with clamps to avoid damages and leakages.

You will find notes concerning the connection of electromagnetic coil in chapter 9.5.

### 3.2 Application of controlled gas springs on premounted units

The application of premounted units offers some advantages. Here the controlled gas springs are placed on a mounting plate according to the desired position in the tool. All necessary cabling and high-pressure hoses are properly installed and secured on the plate.

All used gas springs are later connected and controlled by a 24-pole standard plug. The gas springs can be operated individually as well as in combination according to the design.

For this see also designs of the control panels chapter 5.3.

The premounted unit can easily be installed respectively demounted during maintenance works at the tool. Always pay attention that the electrical cable and the high-pressure hoses are not squeezed. If necessary, replace damaged components.

A filling pressure table created for this unit is enclosed. It facilitates the adjustment of a defined force over the filling pressure. Fix the table on the tool.

Example of a filling pressure table see annex 9.6.



## Controlled gas spring systems SN2875 / SN2882 / SN2883 / SN2884

### 4. Control panels SN2960 / SN2962 / SN2963 / SN2965

Differently charged gas springs can cause a canting of the tool.

By connecting of the gas springs with high-pressure hoses, it is guaranteed that all gas springs have the same pressure.

Due to a control panel (SN2960 / SN2962 / SN2963 / SN2965) fitted on the tool, all gas springs are simultaneously filled or released.

By using the manometer in the control panel, the filling pressure can be controlled at each time.

#### 4.1 Types

The program of STRACK NORMA includes different types for such applications.

SN2960

SN2962

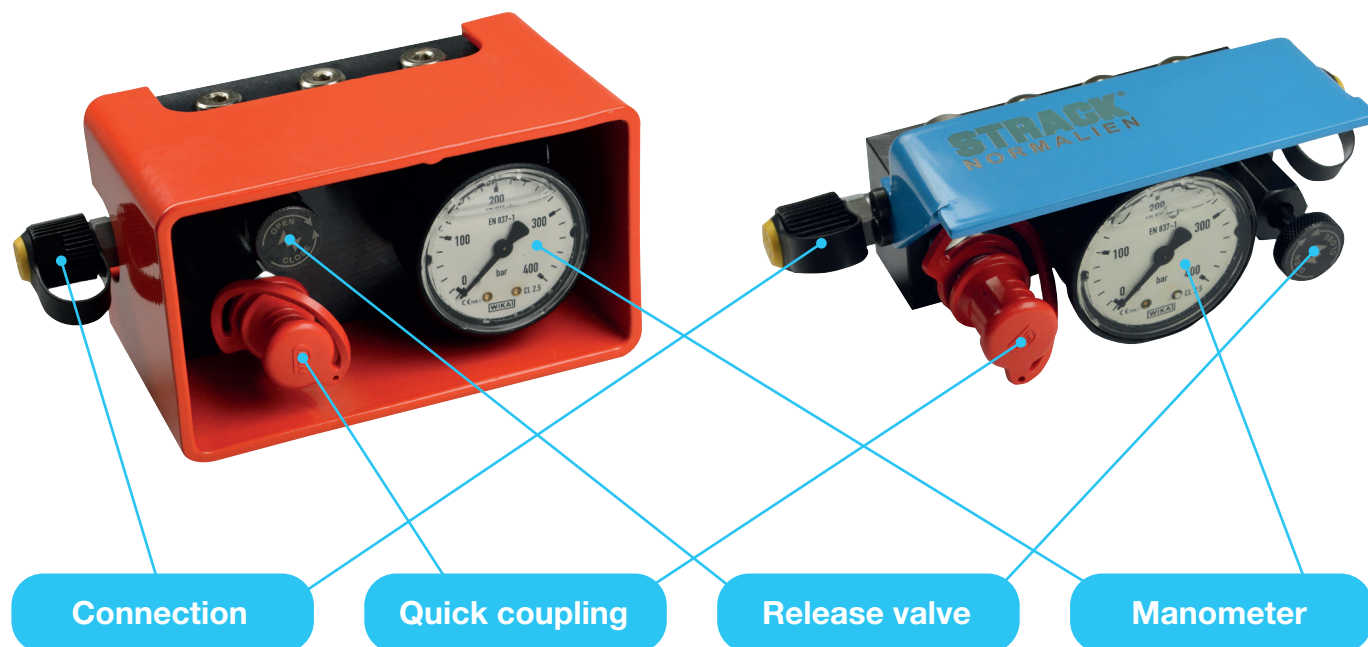

(Continuation next page)

01.2024

## Controlled gas spring systems SN2875 / SN2882 / SN2883 / SN2884

### SN2963

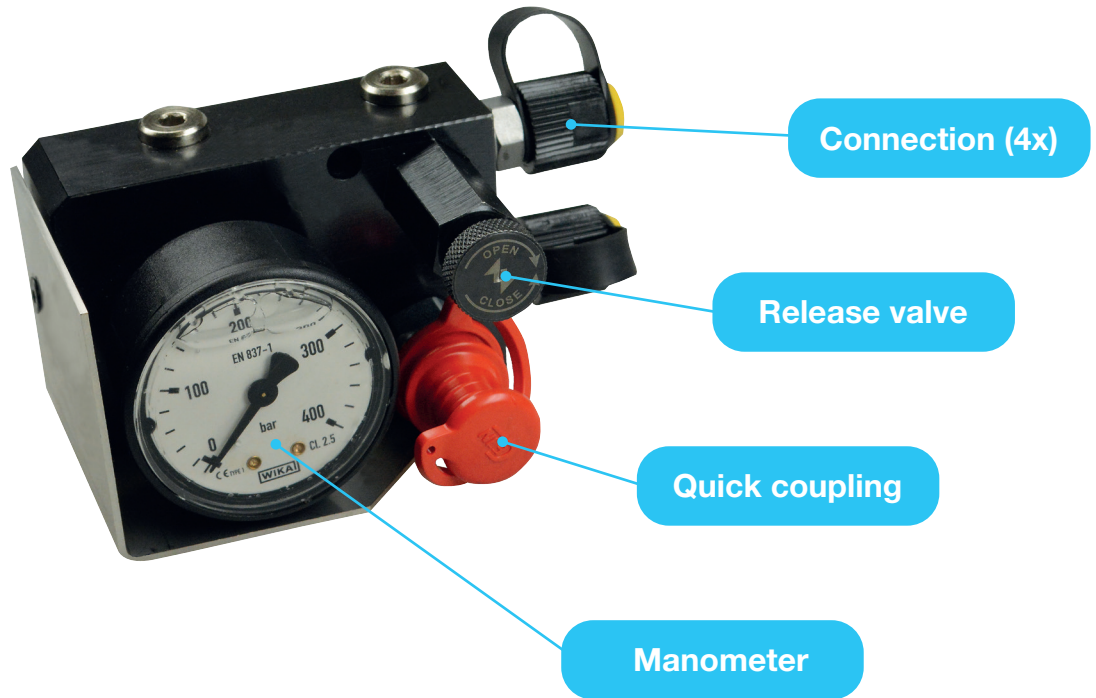

### SN2965

This multi-control panel has 2 up to 8 connection possibilities and can call the pressure at individual gas springs.

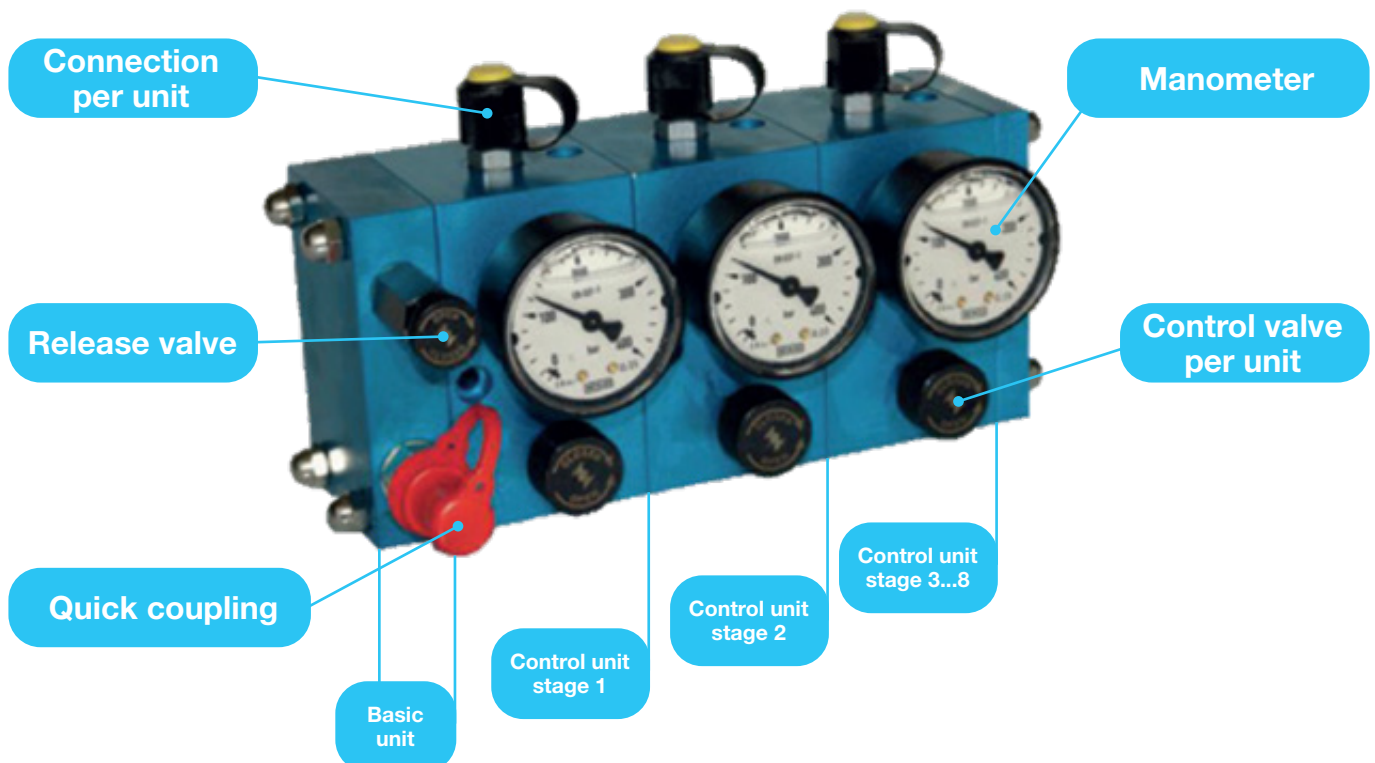

## Controlled gas spring systems SN2875 / SN2882 / SN2883 / SN2884

### 5. Installation

The control panels SN2960 / SN2962 / SN2963 / SN2965 can be connected with a plate by means of screw-fixing.

During the installation of the control panel in the upper part of the tool, the screws must be secured with screw-locking adhesive (medium-strength) due to arising vibration exposure.

#### 5.1 Installation with special design

##### 5.1.1 SN2960

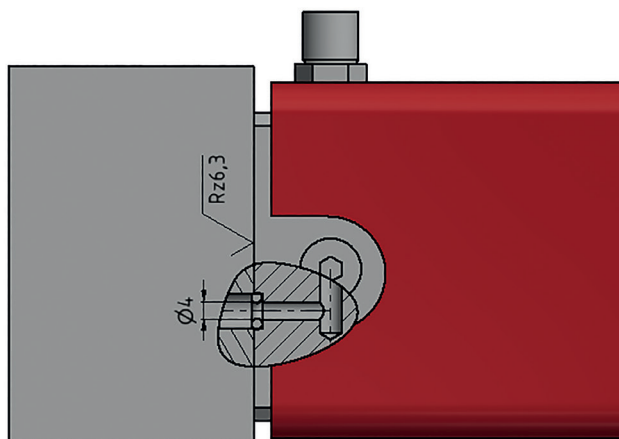

During the installation of a special design, the panel is also fixed by means of screw bore holes, the filling of the plate is effected by means of the boring in the rear side (example at SN2960).

##### 5.1.2 SN2962

Here the filling of the plate is effected by means of an additional connecting piece.

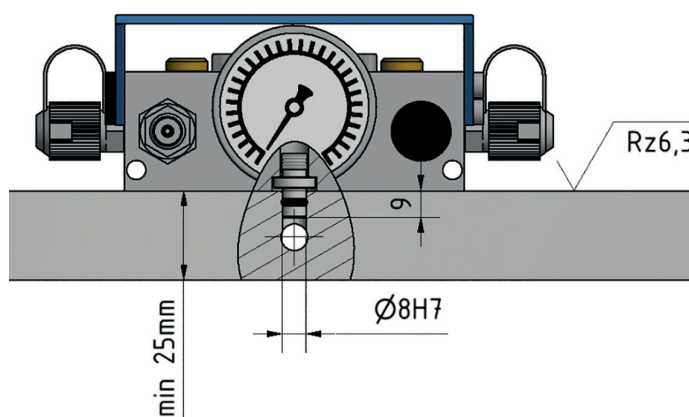

### Controlled gas spring systems SN2875 / SN2882 / SN2883 / SN2884

#### 5.1.3 SN2963

The filling of the tankplate over the control panel SN2963 can be effected as well as it is the case at the control panel SN2960 by means of a boring with o-ring sealing directly on the plate.

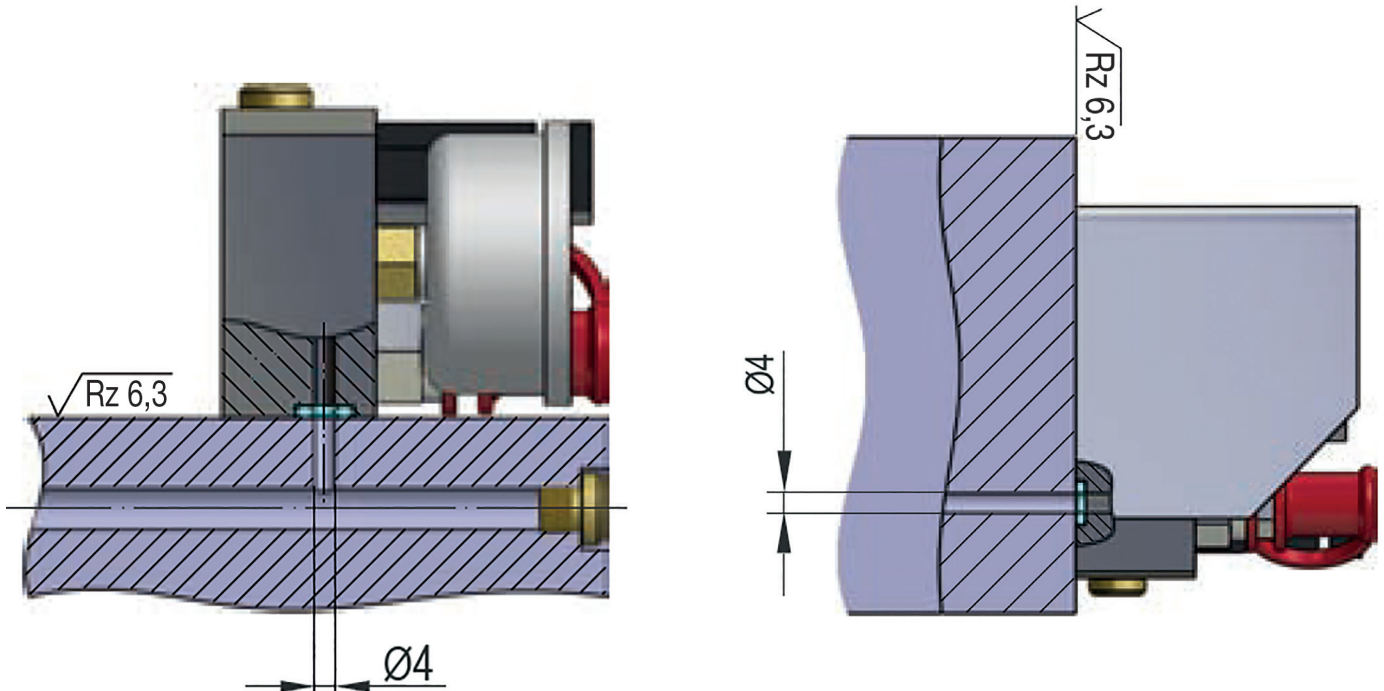

#### 5.1.4 SN2965

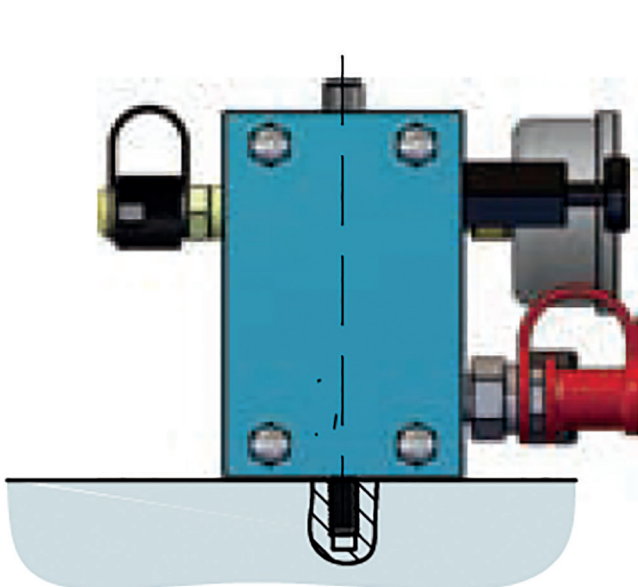

Horizontal fixing of the control panel SN2965 with safety valve on the rear side.

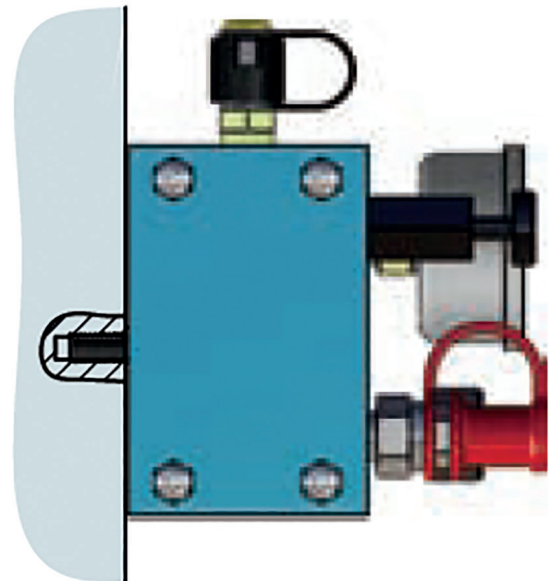

Vertical fixing of the control panel SN2965 with safety valve on the upper side.

## Controlled gas spring systems SN2875 / SN2882 / SN2883 / SN2884

### 6. Initial set-up

#### 6.1 Filling of the system pressure

At the initial start-up after the installation of the STRACK nitrogen gas spring systems, the system must be filled.

Proceed as follows:

#### ATTENTION!



During all works at the STRACK nitrogen gas spring system, the applicable operating safety regulation paragraph 3 must be considered. The initial start-up and operation of the STRACK gas spring system must exclusively be done by personnel which has been trained and instructed by STRACK.

1. Drive the press in the top dead centre and stop it there.
2. Close the release valve of the used control panel.

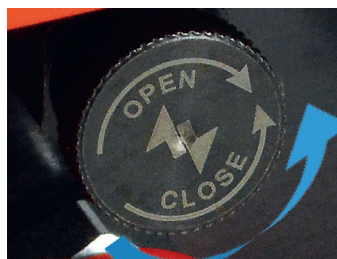

3. Connect the charging hose of the pressure regulator SN2967 on one side to the quick coupling of the control fitting and on the other side to the nitrogen bottle. Adjust the pressure reducer to maximal gas spring filling pressure, e.g. 150 bar.

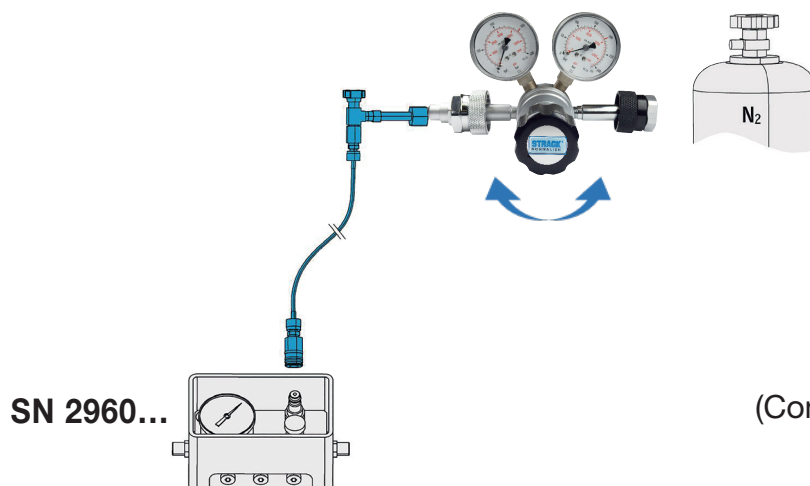

(Continuation next page)

## Controlled gas spring systems SN2875 / SN2882 / SN2883 / SN2884

4. Open the shut-off valve of the nitrogen bottle.
5. Open slowly the valve (1) at the charging hose.

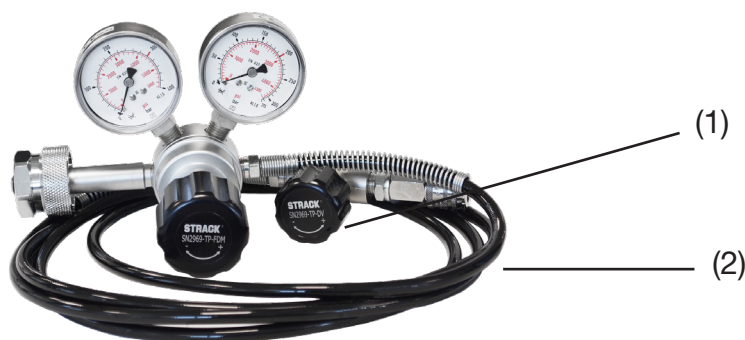

Now fill the whole system with nitrogen. After the piston rods are completely extended, you can continue to open the valve (1) at the charging hose to accelerate the charging process. Adjust the pressure how you need it later. This pressure must lie between 50 and 200 bar. Observe that the system pressure can slightly decrease after the initial filling due to system constraints.

6. Close the valve (1) at the charging hose (2) as well as the valve at the nitrogen bottle.
7. Decouple the charging hose from the control panel.

Now the system pressure is the same in all gas springs.

### NOTE



Decouple the nitrogen bottle during the operation of the gas spring system.

## 6.2 Modification of the system pressure of the gas springs

The control panels allow a simultaneously control of several gas springs.

## Controlled gas spring systems SN2875 / SN2882 / SN2883 / SN2884

### 6.3 Release of the pressure at a gas spring bloc

Now open slowly the release valve and observe the manometer of the gas spring, which should be reduced in pressure.

Close the release valve at the desired pressure.

#### ATTENTION!



Please consider the respective indicated minimal- and maximal filling pressure for the gas springs contained in the catalogue.

Now the gas spring has the selected initial force.

### 6.4 Increase of the pressure at a gas spring

- Connect the charging hose (2) to the filling valve (quick coupling) (1) of the control fitting, connect the charging hose (2) to the pressure reducer of the nitrogen cylinder.
- Open the release valve of the nitrogen bottle.
- Open slowly the valve at the charging hose. Now fill the selected gas springs with nitrogen. (Force see table in annex)
- Close the valve at the charging hose as well as the valve at the nitrogen bottle.
- Decouple the charging hose (2) from the control panel.

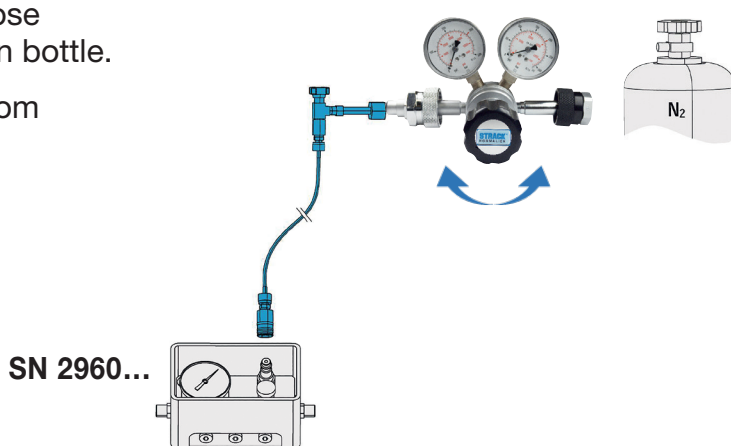
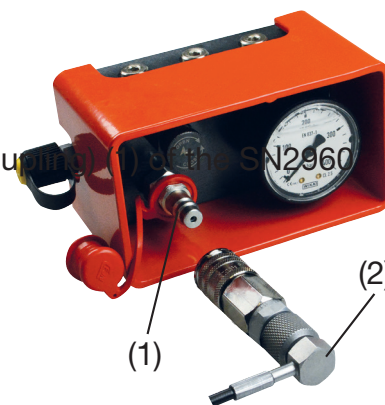

#### NOTE



If the control panel SN2960 is equipped with a pressure controller, disturbances can occur, if the adjusted pressure at the control panel is under the adjusted minimum pressure of the pressure controller.

Thus, the press can be blocked.

In such a case, you have either to increase the pressure again or to adjust the pressure controller to this new value.

## Controlled gas spring systems SN2875 / SN2882 / SN2883 / SN2884

### 7. Pressure controller

To provide security in the tool, you can optionally screw a pressure controller SN2997 or SN2998 on the control panel.

The pressure controller opens or closes an electrical current circuit when an adjustable pressure value is achieved. Due to the increase of the pressure a membrane respectively a piston is moved.

The deflection of the membrane respectively the stroke of the piston depends on the compressive force and the adjustable spring preload.

At a defined deflection of the membrane respectively a defined stroke of the piston, a micro-switch is actuated which opens respectively closes the electrical contacts (changeover contact).

#### SN2997

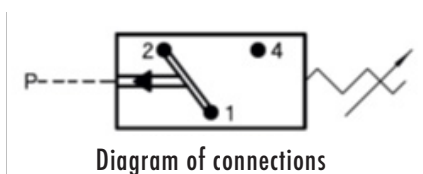
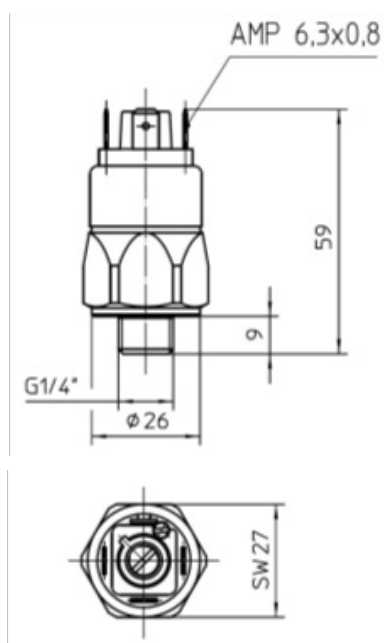

Technical data	
Pressure range	50 - 200 bar
Switching accuracy	± 5 bar at room temperature
Overpressure protection	600 bar static, dynamic value, 30-50 % lower
Switching frequency	200 / min.
Switching pressure difference (hysteresis)	10 - 30 % adjustable
Sealing material	NBR (Buna N)



## Controlled gas spring systems SN2875 / SN2882 / SN2883 / SN2884

Technical data	
Temperature range	-40°C ... +100°C
Switching capacity	4 A / 250 V
Protection type	IP 65, Klemen IP00
Housing material	Galvanized steel CR-(VI)-free
Mechanical service life	1.000.000 switching cycles

### SN2998

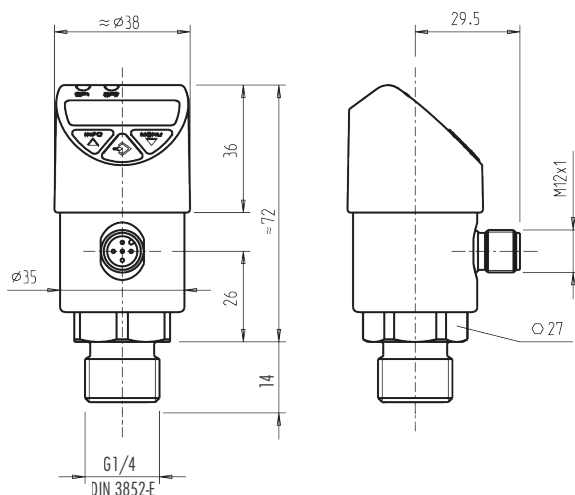

Technical data	
Pressure range	0 - 250 bar
Switching accuracy	± 5
Overpressure protection	600 bar static, dynamic value, 30-50 % lower
Switching pressure difference (hysteresis)	10 - 25 %
Sealing material	NBR
Temperature range	-20°C ... +80°C
Switching electricity	max. 250 mA
Protection type	IP 65, IP 67
Mechanical service life	100.000.000 switching cycles

### Controlled gas spring systems SN2875 / SN2882 / SN2883 / SN2884

## 7.1 Safety features

According to the latest VDI standard, gas springs must be equipped with safety features against overpressure, overstroke and free extension of the piston rod.

The springs must be marked with the feature which is existing in the spring.

According to the VDI standard, there is a special laser inscription, which applies for all gas spring producers.



Protection against shooting out of the piston rod



Protection against overstroke



Protection against overpressure

### Controlled gas spring systems SN2875 / SN2882 / SN2883 / SN2884

## 8. Production

During the production, no special precautions must be taken exceeding the applicable industrial safety regulation paragraph 3.

#### NOTE



Assure that STRACK nitrogen gas spring systems, particularly the cylinders are not immersed in fluid.

If you use for example aggressive drawing oils in the production, create a controlled flow (drainage borings, cutouts, etc.) in order that the fluids are led away from the cylinders. Thus, seal damages can be avoided.

#### TIP

Control the nitrogen pressure at the control panel at regular intervals to determine modifications in the pressure level in time.

- It is absolutely necessary to keep in mind that the maximal operating parameters forming the basis of the design may not be exceeded, because otherwise the gas spring system will be damaged.

## 9. Maintenance of the system

If necessary, the maintenance is only to be effected by STRACK NORMA to avoid functional problems.

#### STRACK NORMA GmbH & Co. KG

Königsberger Straße 11  
D-58511 Lüdenscheid

Tel.: +49 2351 8701 - 0  
Fax: +49 2351 8701 - 100  
E-Mail: [info@strack.de](mailto:info@strack.de)  
Internet: [www.strack.de](http://www.strack.de)

In addition to nitrogen, the system is filled with oil.  
Air inclusions in the oil will result in an uncontrolled extension of the piston rod.

### Controlled gas spring systems SN2875 / SN2882 / SN2883 / SN2884

## 9.1 Safety data sheet concerning the used hydraulic oil

The oil used in the controlled gas spring system is a hydraulic oil.  
You will find the safety data sheet for this oil under the following link:

<http://www.strack.de/download/safety/DROP HM 46 S - Hydraulic mineral-based oil>

## 10. Standstill and storage

### Standstill

During the standstill of the press no special precautions must be taken exceeding the usually applicable regulations at gas spring controlled applications.

### Storage

It makes sense to release the system pressure for the transport or storage of the tool with a mounted STRACK nitrogen gas spring system.

The components of the tool which can retract uncontrolled by the reduction of the system pressure during a longer storage, must be secured (UVV Accident Prevention Regulation).

- Before operating the tool again, control the system pressure.  
If you must increase the system pressure again, proceed as described in chapter 5.

## Controlled gas spring systems SN2875 / SN2882 / SN2883 / SN2884

### 11. ANNEX

#### 11.1 Functional operation

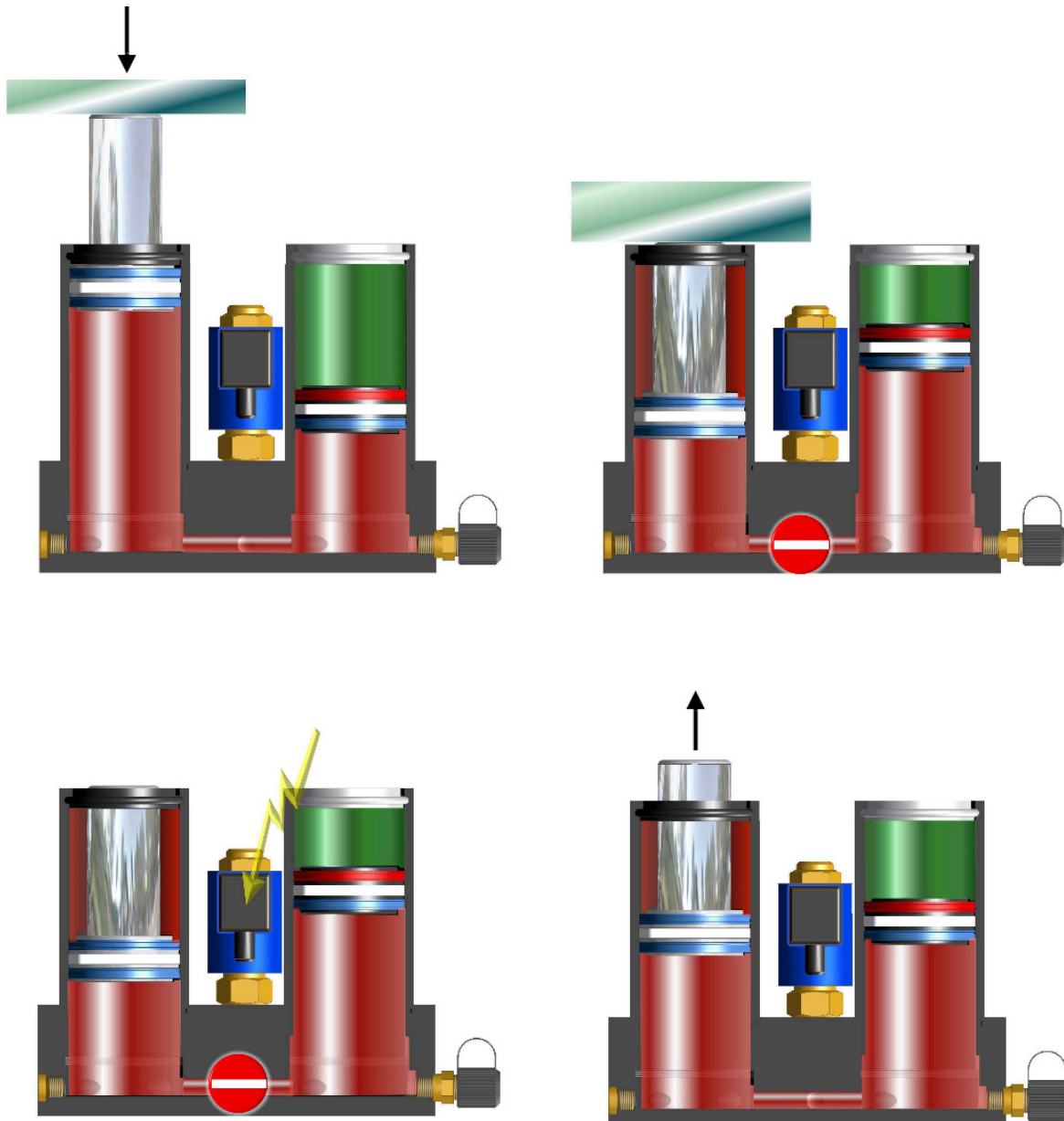

## Controlled gas spring systems SN2875 / SN2882 / SN2883 / SN2884

### 11.2 Catalogue page SN2875-4500

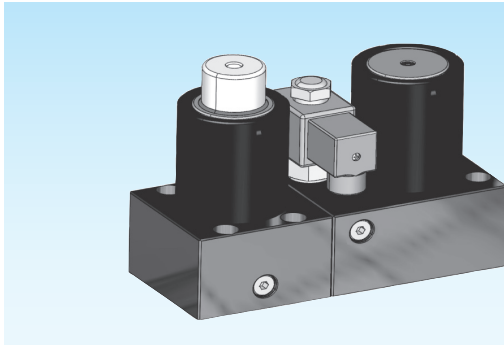

Druckmedium	Pressure medium	Médium de pression	Stickstoff (N <sub>2</sub> )
Max. Fülldruck	Max. filling pressure	Pression de rempl. max.	<b>150 bar</b>
Min. Fülldruck	Min. filling pressure	Pression de rempl. min.	<b>50 bar</b>
Max. Betriebstemperatur	Max. working temperature	Température de service max.	<b>60 °C</b>
Temperaturabhängige Druckerhöhung	Pressure increase due to temperature	Accroissement de pression sous l'influence de la temp.	<b>0,33 %/1 °C</b>
Max. Kolbengeschwindigkeit	Max. piston speed	Vitesse max. du piston	<b>18 m/min.</b>
Max. empfohlene Hübe	Max. recommended strokes	Course recommandé max.	<b>10-40* s/min.</b>

**Höhere Geschwindigkeit auf Anfrage**  
Higher speed on request  
Vitesse supérieure sur demande

#### Erforderliche Angaben des Kunden

Arbeitshub: \_\_\_\_\_ mm  
Pressengeschwindigkeit: \_\_\_\_\_ m/min  
Maximale Pressenrate: \_\_\_\_\_ Hübe/min



#### Required information of the customer

Working stroke: \_\_\_\_\_ mm  
Press speed: \_\_\_\_\_ m/min  
Maximum press rate: \_\_\_\_\_ Strokes/min

#### Informations indispensables du client

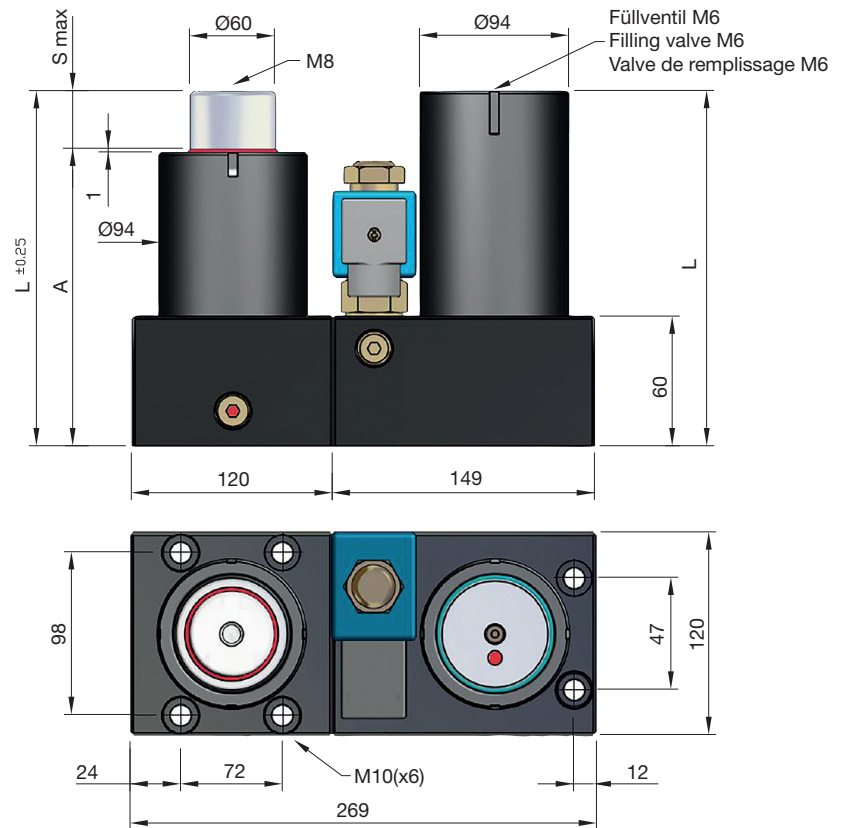
Course de travail: \_\_\_\_\_ mm  
Vitesse de presse: \_\_\_\_\_ m/min  
Nombre de pression maximale: \_\_\_\_\_ Courses/min



SN2875-4500-	S	Elektromagnetventil/Electromagnetic valve/ Soupape électromagnétique		A	L	daN	daN	bar	Fa [cm <sup>2</sup> ]
		V	W						
 SN2875-4500-S-V	12	24 V DC	17 W	128	140	4500	4630	150	28,27
	25	110 V AC	17 W	141	166	(±5%)	4890	150	28,27
	38	220 V AC	17 W	154	192		5060	150	28,27
	50		17 W	166	216		5175	150	28,27
	63		17 W	179	242		5265	150	28,27
	80		17 W	196	276		5355	150	28,27
	100		17 W	216	316		5435	150	28,27
	125		17 W	241	366		5505	150	28,27

S = Hub / Stroke / Course

bar = Fülldruck / Filling pressure /  
Pression de remplissage

\* = Maximale Anzahl abhängig von Arbeitsparametern  
Maximum rate will depend on working parameters  
Nombre maximum dépendant des paramètres de travail

## Controlled gas spring systems SN2875 / SN2882 / SN2883 / SN2884

### 11.3 Catalogue page SN2882-4500

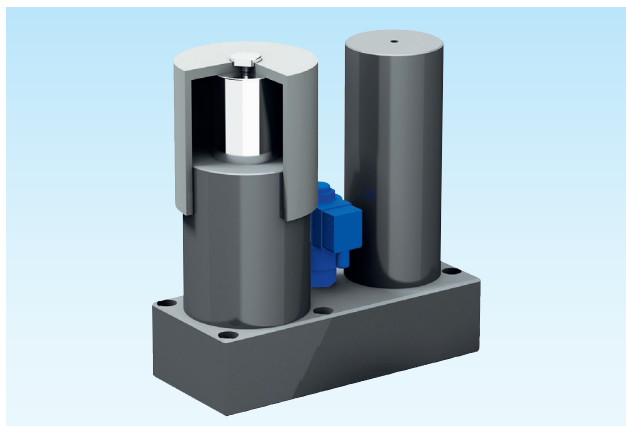

Druckmedium	Pressure medium	Médium de pression	Stickstoff (N <sub>2</sub> )
Max. Fülldruck	Max. filling pressure	Pression de rempl. max.	<b>150 bar</b>
Min. Fülldruck	Min. filling pressure	Pression de rempl. min.	<b>50 bar</b>
Max. Betriebs-temperatur	Max. working temperature	Température de service max.	<b>60 °C</b>
Temperaturabhängige Druckerhöhung	Pressure increase due to temperature	Accroissement de pression sous l'influence de la temp.	<b>0,33 %/1 °C</b>
Max. Kolben-geschwindigkeit	Max. piston speed	Vitesse max. du piston	<b>18 m/min.</b>
Max. empfohlene Hübe	Max. recommended strokes	Course recommandé max.	<b>10-40* S/min.</b>
* = Maximale Anzahl abhängig von Arbeitsparametern	* = Maximum rate will depend on working parameters	* = Nombre maximum dépendant des paramètres de travail	

#### Erforderliche Angaben des Kunden

Arbeitshub: \_\_\_\_\_ mm  
 Pressengeschwindigkeit: \_\_\_\_\_ m/min  
 Maximale Pressenrate: \_\_\_\_\_ Hübe/min



#### Required information of the customer

Working stroke: \_\_\_\_\_ mm  
 Press speed: \_\_\_\_\_ m/min  
 Maximum press rate: \_\_\_\_\_ Strokes/min

#### Informations indispensables du client

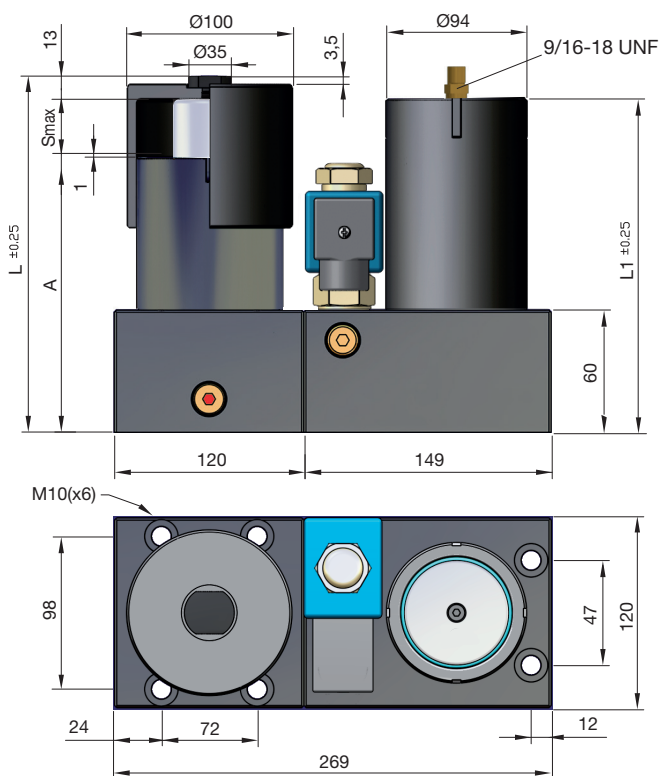
Course de travail: \_\_\_\_\_ mm  
 Vitesse de presse: \_\_\_\_\_ m/min  
 Nombre de pression maximale: \_\_\_\_\_ Courses/min



SN2882-4500-	S	Elektromagnetventil Electromagnetic valve Soupape électromagnétique V*	A	L	L1	daN	daN	bar	Fa [cm <sup>2</sup> ]		
 SN2882-4500-S	50	24	166	229	216	4500 (±5%)	5175	150	28,27		
	80		196	289	276				5355	150	28,27
	125		241	379	366				5505	150	28,27
S = Hub / Stroke / Course bar = Fülldruck / Filling pressure / Pression de remplissage V* = 24 V DC, 17 W											
 											

(Continuation next page)

## Controlled gas spring systems SN2875 / SN2882 / SN2883 / SN2884

### 11.4 Catalogue page SN2883-4500

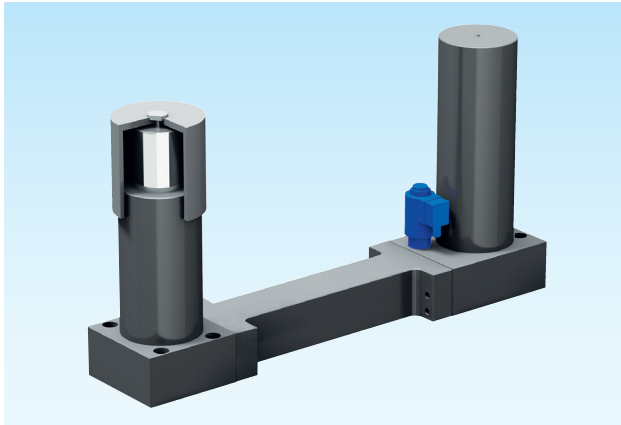

Druckmedium	Pressure medium	Médium de pression	Stickstoff (N <sub>2</sub> )
Max. Fülldruck	Max. filling pressure	Pression de rempl. max.	<b>150 bar</b>
Min. Fülldruck	Min. filling pressure	Pression de rempl. min.	<b>50 bar</b>
Max. Betriebs-temperatur	Max. working temperature	Température de service max.	<b>60 °C</b>
Temperaturabhängige Druckerhöhung	Pressure increase due to temperature	Accroissement de pression sous l'influence de la temp.	<b>0,33 %/1 °C</b>
Max. Kolben-geschwindigkeit	Max. piston speed	Vitesse max. du piston	<b>18 m/min.</b>
Max. empfohlene Hübe	Max. recommended strokes	Course recommandé max.	<b>10-40* S/min.</b>
* = Maximale Anzahl abhängig von Arbeitsparametern			* = Maximum rate will depend on working parameters
* = Nombre maximum dépendant des paramètres de travail			

#### Erforderliche Angaben des Kunden

Arbeitshub: \_\_\_\_\_ mm  
 Pressengeschwindigkeit: \_\_\_\_\_ m/min  
 Maximale Pressenrate: \_\_\_\_\_ Hübe/min





#### Required information of the customer

Working stroke: \_\_\_\_\_ mm  
 Press speed: \_\_\_\_\_ m/min  
 Maximum press rate: \_\_\_\_\_ Strokes/min

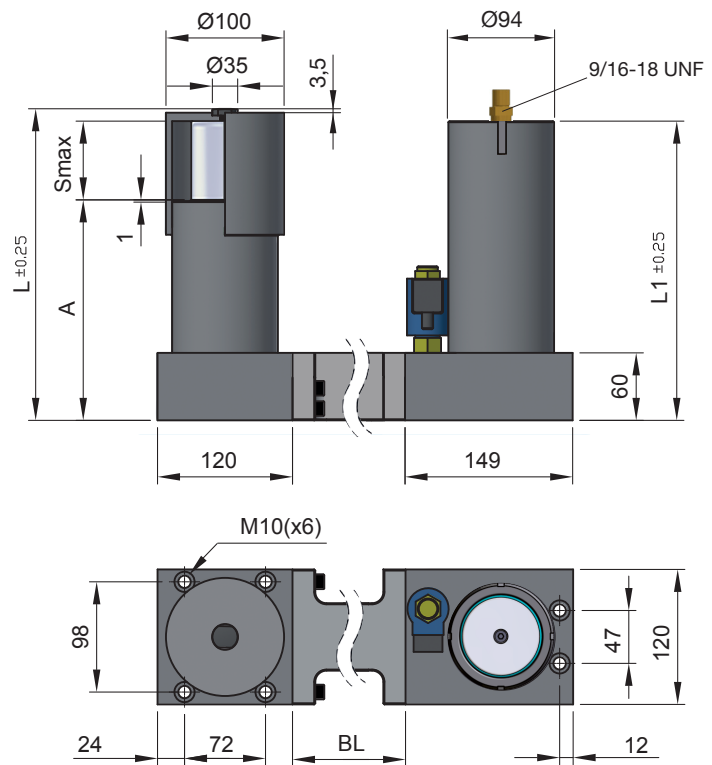
#### Informations indispensables du client

Course de travail: \_\_\_\_\_ mm  
 Vitesse de presse: \_\_\_\_\_ m/min  
 Nombre de pression maximale: \_\_\_\_\_ Courses/min



SN2883-4500-	S	BL	Elektromagnetventil Electromagnetic valve Soupape électromagnétique V*	A	L	L1	daN	daN	bar	Fa [cm <sup>2</sup> ]
 SN2883-4500-S-BL 	50	min.	24	166	229	216	4500 (±5%)	5175	150	28,27
	80	170		196	289	276				
S = Hub / Stroke / Course	125	max.		241	379	366		5505	150	28,27
bar = Fülldruck / Filling pressure / Pression de remplissage		1400								
V* = 24 V DC, 17 W										
  										



## Controlled gas spring systems SN2875 / SN2882 / SN2883 / SN2884

### 11.5 Catalogue page SN2884-4500

Gesteuerte Gasdruckfedern	Controlled gas springs	Ressorts à gaz contrôlés		
	Druckmedium	Pressure medium	Médium de pression	<b>Stickstoff (N<sub>2</sub>)</b>
	Max. Fülldruck	Max. filling pressure	Pression de rempl. max.	<b>150 bar</b>
	Min. Fülldruck	Min. filling pressure	Pression de rempl. min.	<b>50 bar</b>
	Max. Betriebs-temperatur	Max. working temperature	Température de service max.	<b>60 °C</b>
	Temperaturabhängige Druckerhöhung	Pressure increase due to temperature	Accroissement de pression sous l'influence de la temp.	<b>0,33 %/°C</b>
	Max. Kolben-geschwindigkeit	Max. piston speed	Vitesse max. du piston	<b>0,5 m/s.</b>
	Max. empfohlene Hübe	Max. recommended strokes	Course recommandé max.	<b>8 - 25* S/min.</b>
* = Maximale Anzahl abhängig von Arbeitsparametern	* = Maximum rate will depend on working parameters	* = Nombre maximum dépendant des paramètres de travail		

#### Erforderliche Angaben des Kunden

Arbeitshub<sup>1)</sup>: \_\_\_\_\_ mm  
 Pressengeschwindigkeit: \_\_\_\_\_ m/min  
 Maximale Pressenrate: \_\_\_\_\_ Hübe/min

<sup>1)</sup> Die 100 % Ausnutzung des Hubes **S** reduziert die max. möglichen Arbeitsparameter. 10 % Hubreserve sind in der Werkzeugkonstruktion einzukalkulieren.

#### Required information of the customer

Working stroke<sup>1)</sup>: \_\_\_\_\_ mm  
 Press speed: \_\_\_\_\_ m/min  
 Maximum press rate: \_\_\_\_\_ Strokes/min

<sup>1)</sup> The 100 % utilization of the stroke **S** reduces the max. possible working parameters. 10 % stroke reserve is to be calculated in the tool construction.

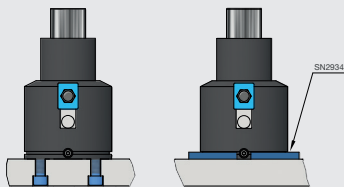

Type 1

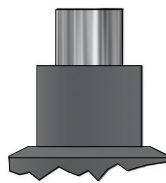

Type 2

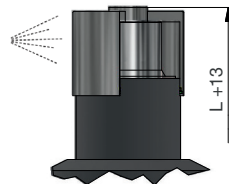

Type 3

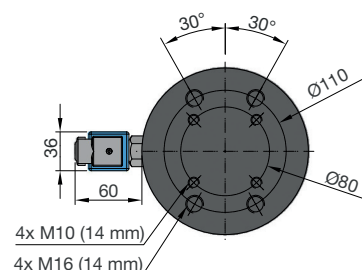
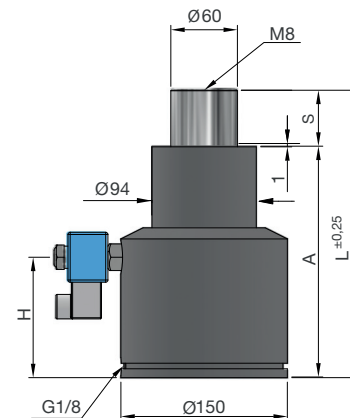
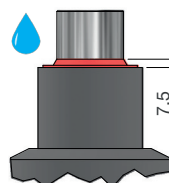

### SN2884-4500

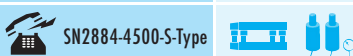

S = Hub<sup>1)</sup> / Stroke<sup>1)</sup> / Course<sup>1)</sup>

bar = Fülldruck / Filling pressure /  
Pression de remplissage



S	Type	A	L	H	daN	daN	bar	Fa [cm <sup>2</sup> ]
50	1/2/3	208	258	88,5		5810		28,27
75	1/2/3	245	320	100,5	4500 ±5% (20°C)	6380	150 (20°C)	28,27
100	1/2/3	282	382	112,5		6450		28,27
125	1/2/3	319	444	124,5		6650		28,27

## Controlled gas spring systems SN2875 / SN2882 / SN2883 / SN2884

### 11.6 Important information for the order

Controlled gas spring systems are individually planned, designed and produced for each case of application.

To be able to secure a trouble-free and efficient production process, at least the following information is required:

- Contact person in the plant (for technical queries)
- Telephone number
- E-Mail-address

**Additionally, the determined operating parameters are required:**

**For the systems SN2875, SN2882 and SN2884:**

- Working stroke in mm
- Press speed in m/min
- Maximal press rate in strokes/min



## Controlled gas spring systems SN2875 / SN2882 / SN2883 / SN2884

### For the system SN2883:

- Working stroke mm
- Press speed m/min
- Maximal press rate in strokes/min
- Block length of the block between the modules in mm

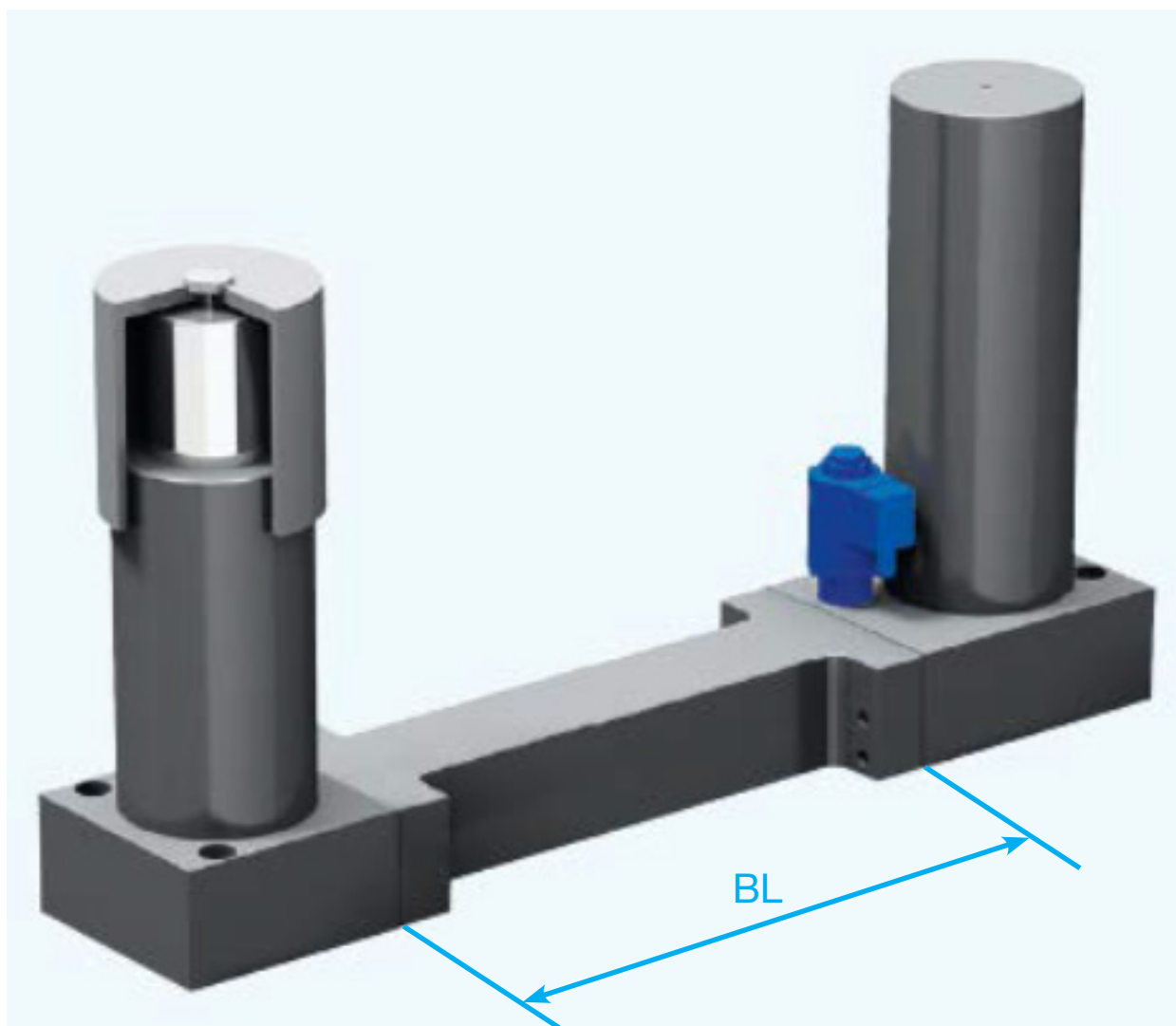

## Controlled gas spring systems SN2875 / SN2882 / SN2883 / SN2884

### 11.7 Connection of the electromagnetic coil

The magnetic coil is plugged on the core mounted in the gas spring and is fixed with the retaining nut.

Please, only original components use to avoid malfunctions.

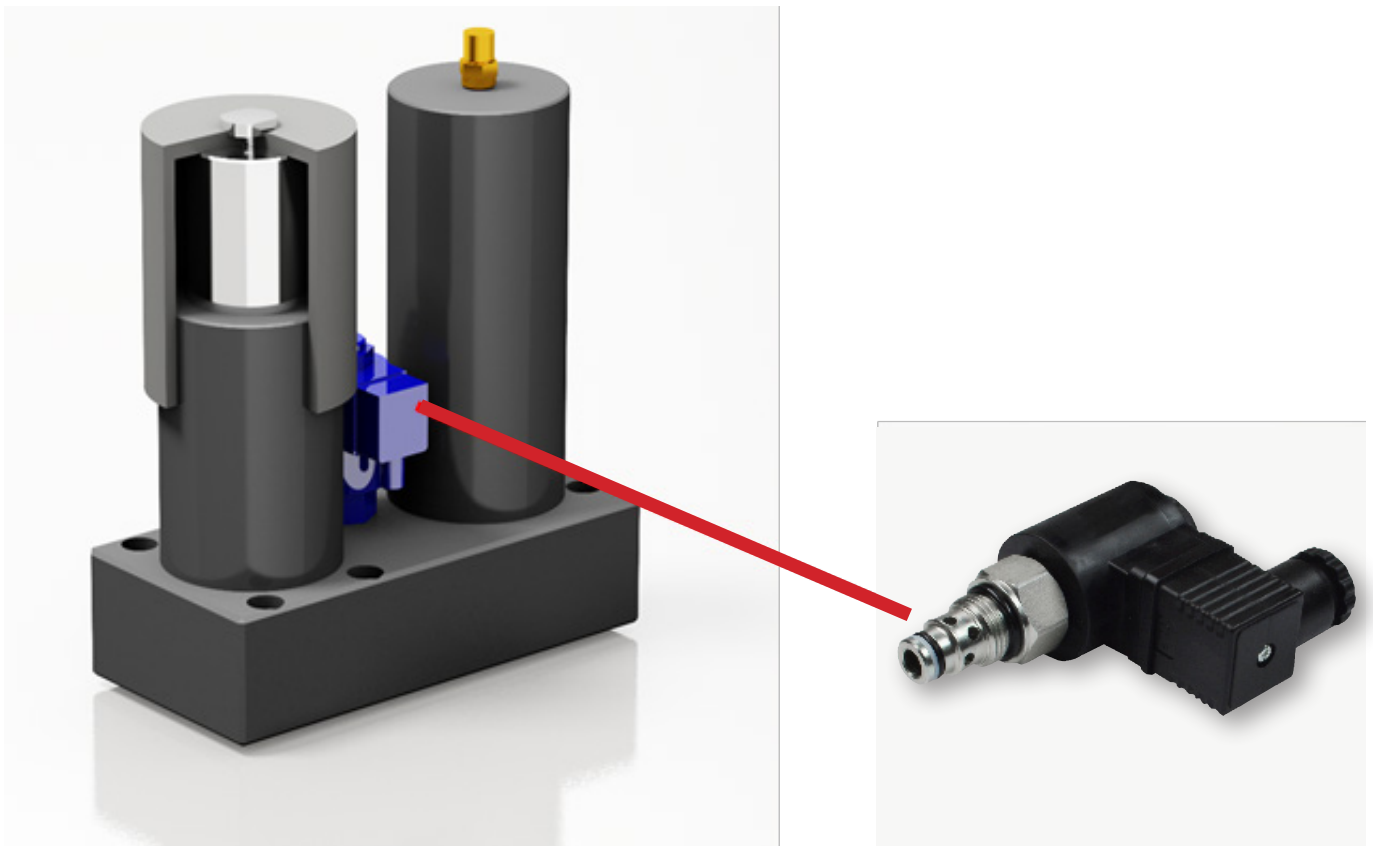

To guarantee a correct function and a long service life of the coil, voltage fluctuations of the nominal voltage may not exceed more than  $\pm 10\%$ .

Lateral pressure on the magnetic core can cause internal damage of the check valve.

## Controlled gas spring systems SN2875 / SN2882 / SN2883 / SN2884

### 11.7.1 Technical data magnetic coil

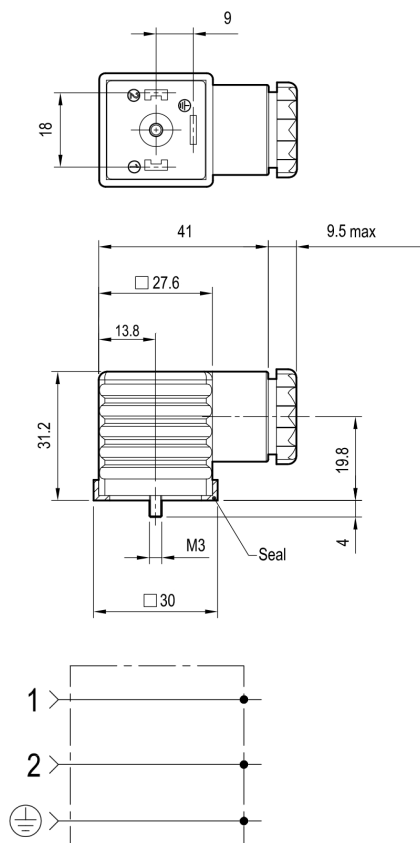

Technical data connector	
Nominal voltage	24 V DC
Number of the poles	2 + earth
Nominal current capacity	10 A
Maximal current capacity	16 A
Maximal wire cross-section	1.5 mm <sup>2</sup>
Cable diameter	6 - 8 mm
Isolation class	H 180°C
Protection class	IP 67 DIN 40050

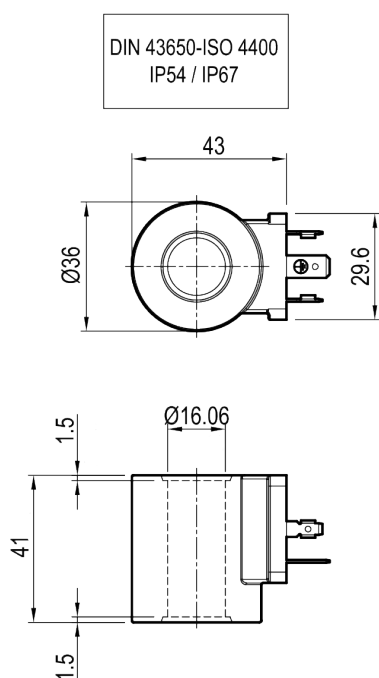

Technical data magnetic coil	
Nominal voltage	24 V DC
Resistance (20 - 25°C)	28,4 Ω
Power (cold coil)	20 W
Current (cold coil)	0,83 A
Current (hot coil)	0,54 A
Ambient temperature range	-30 °C / +90 °C



(Continuation next page)

## Controlled gas spring systems SN2875 / SN2882 / SN2883 / SN2884





## Controlled gas spring systems SN2875 / SN2882 / SN2883 / SN2884

### 11.8 Filling pressure table (example)

Gas spring SN2882-4500	Number gas spring 1	Power table for whole system with 1 gas springs					
		Filling pressure [bar]	Piston surface Fa [cm <sup>2</sup> ]	Travelled stroke [mm]			
				0	50	80	125
		 daN	 daN				
50	28.27	1414	1725	1785	1835		
55		1555	1898	1963	2018		
60		1696	2070	2142	2202		
65		1838	2243	2320	2385		
70		1979	2415	2499	2569		
75		2120	2588	2677	2752		
80		2262	2760	2856	2936		
85		2403	2933	3034	3119		
90		2544	3105	3213	3303		
95		2686	3278	3391	3486		
100		2827	3450	3570	3670		
105		2968	3623	3748	3853		
110		3110	3795	3927	4037		
115		3251	3968	4105	4220		
120		3392	4140	4283	4403		
125		3534	4313	4462	4587		
130		3675	4485	4640	4770		
135		3816	4658	4819	4954		
140		3958	4830	4997	5137		
145		4099	5003	5176	5321		
150	4241	5175	5354	5504			
	Build-up factor:	1	1.22	1.26	1.30		

### Controlled gas spring systems SN2875 / SN2882 / SN2883 / SN2884

Gas spring SN2882-4500	Number gas spring 8	Power table for whole system with 8 gas springs			
Filling pressure [bar]	Piston surface Fa [cm <sup>2</sup> ]	Travelled stroke [mm]			
		0	50	80	125
		 daN	 daN		
50	28.27	11308	13800	14278	14678
55		12439	15180	15706	16146
60		13570	16560	17134	17614
65		14700	17940	18562	19082
70		15831	19320	19990	20550
75		16962	20700	21417	22017
80		18093	22080	22845	23485
85		19224	23460	24273	24953
90		20354	24840	25701	26421
95		21485	26220	27129	27889
100		22616	27600	28557	29357
105		23747	28980	29984	30824
110		24878	30360	31412	32292
115		26008	31740	32840	33760
120		27139	33120	34268	35228
125		28270	34500	35696	36696
130		29401	35880	37124	38163
135		30532	37260	38551	39631
140		31662	38640	39979	41099
145		32793	40020	41407	42567
150	33924	41400	42835	44035	
	Build-up factor:	1	1.22	1.26	1.30



Controlled gas spring systems SN2875 / SN2882 / SN2883 / SN2884

## 11.9 Examples for mounting plates ready to be installed with controlled gas spring system

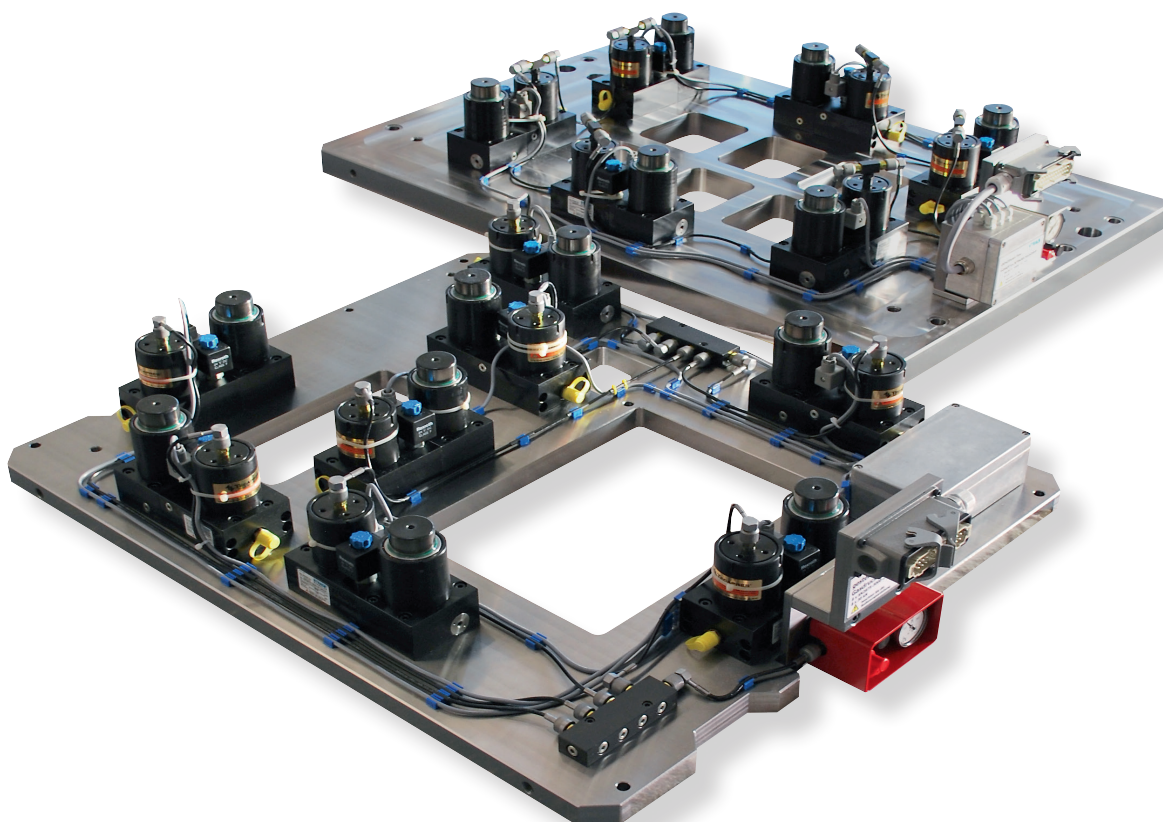
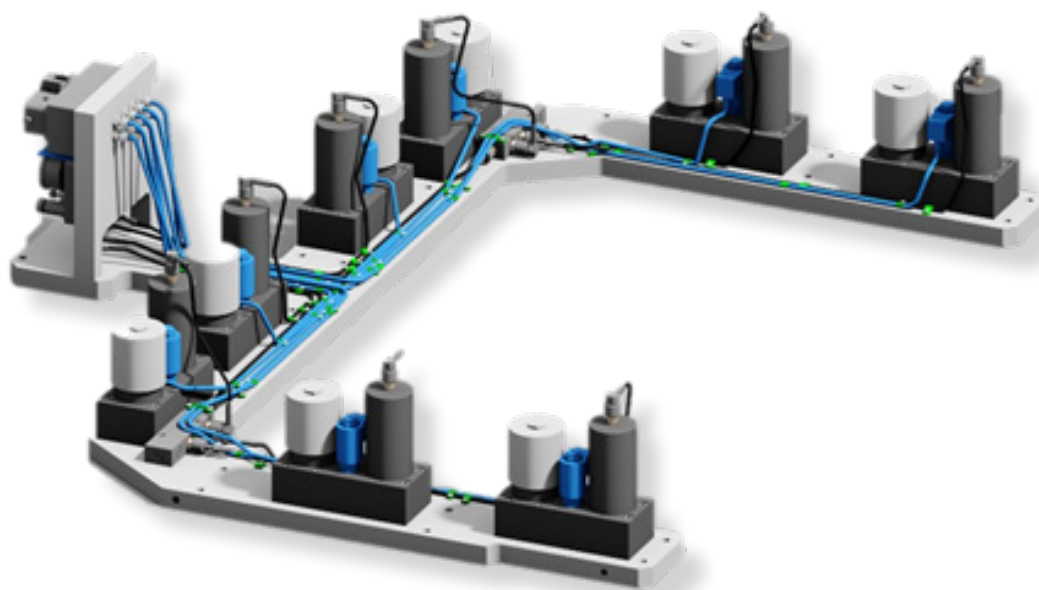

### Controlled gas spring systems SN2875 / SN2882 / SN2883 / SN2884

#### 11.10 Common errors

PROBLEM	POSSIBLE REASON	SOLUTION
The cylinder has not its full force	Gas leak	<ul style="list-style-type: none"> <li>▶ Control if the pressure accumulator has the right pressure If required charge the accumulator with N2.</li> <li>▶ Control if there are leaks at the control panel, the connections, the hoses. Correct or replace and charge with N2</li> <li>▶ If the problem is not solved, send it to the technical service for verification and preventive maintenance (exchange of seals)</li> </ul>
The piston rod doesn't stop at its blocking position, but the gas spring maintains its full force	(Initial installation) faulty electrical signal	<ul style="list-style-type: none"> <li>▶ Control electrical connection and connect correctly Control the polarity</li> </ul>
	(used gas spring) damaged coil	<ul style="list-style-type: none"> <li>▶ Control coil operation and if necessary exchange coil-electrical valve</li> <li>▶ If the coil is o.k. send it back to the technical service for verification</li> </ul>
During stop the piston rod doesn't remain and extends slowly	Damaged internal check valves	<ul style="list-style-type: none"> <li>▶ Send it back to the technical service</li> </ul>
Strange behaviour is observed when stopping: - The piston rod doesn't remain and extends slowly - Excessive spring back	The oil chamber is impurified with gas	<ul style="list-style-type: none"> <li>▶ Send it back to the technical service</li> </ul>
The piston rod doesn't extend by 100 %	Oil leak	<ul style="list-style-type: none"> <li>▶ Send it back to the technical service</li> </ul>

# STRACK®

## NORMALIEN

### STRACK NORMA GmbH & Co. KG

Königsberger Str. 11  
D-58511 Lüdenscheid  
Postfach 16 29  
D-58466 Lüdenscheid

**Tel** +49 2351 8701-0  
**Fax** +49 2351 8701-100  
**Mail** [info@strack.de](mailto:info@strack.de)  
**Web** [www.strack.de](http://www.strack.de)



Management  
System  
ISO 9001:2015

[www.tuv.com](http://www.tuv.com)  
ID 0910092006